

BUILDING CRITERIA FOR NEW CONSTRUCTION

55

ELSIE STREET PLAN

DESIGN GUIDELINES

ELZIE STREET PLAN

It is hoped that the following guidelines will serve as an aid to future designers and builders of residences on the 100 Block of Elsie Street. As described elsewhere in this report, the Elsie Street neighborhood is a very special place, both in the hearts and minds of its residents and in its physical relationship to the rest of the city. At the instigation of this study, an attempt was made to define the various elements that presently give the area its distinctive character. A thorough inventory of the housing stock, both on the block in question and the streets in near proximity to it, was taken. Predominant architectural components were examined as was the relationship of individual buildings to their lots and their immediate neighbors. The design guidelines are an effort to capture the spirit of what we noticed and to set up a formula for the construction of new housing that will insure, as much as possible, the continued existence of that unique character.

Of course, we make no pretence of being fully comprehensive or of covering all bases. There can be no guarantee that if every guideline is met, the resulting structure will be a paragon of beauty or functionality. However, clearly, many commonly-made mistakes will be avoided and the chance of shoebox-like ticky-tacky houses covering the hillside will be minimized.

We have tried very hard to make the guidelines prescriptive rather than restrictive. The intent is not to induce dull uniformity but rather to encourage inventive diversity while conforming to the patterns of development which have made northwest Bernal Heights as humanly scaled as it is today.

The design guidelines are broken down as follows:

1. 9'-0" CURB CUT/SINGLE CAR GARAGE DOOR
2. LANDSCAPING/FRONT YARD SETBACKS/STREET TREES
3. ENTRY TREATMENT
4. BUILDING BULK AND ARCHITECTURAL MASSING
5. SIDEYARDS
6. ROOF TREATMENT/STEP WITH SLOPE ALONG STREET
7. FACADE ELEMENTS
8. COLORS AND MATERIALS

All drawings and photographs used to illustrate the guidelines depict actual buildings existing within a four-block radius of the 100 Block of Elsie Street.

9'-0" CURB CUT / SINGLE CAR GARAGE DOOR

PROBLEM:

There is a severe lack of parking spaces in the area due to the fact that 45% of the existing houses do not have garages, and the streets are narrow. This often results in people being forced to park on the sidewalks or far from their homes. On the 100 block of Elsie Street, the problem is even worse because the 16'-0" roadway allows parking on one side only. In addition, of the fifteen existing houses, only four have garages. New residential construction that utilizes double car garages exacerbates the problem by eliminating any on-street parking in front of the house.

RULE:

Garage doors shall be limited to a 10'-0" width. Curb cuts shall be 9'-0" and placed so as to create a 16'-0" curb space within the 25'-0" width of the lot to provide one full parking space on the street. In addition, the garage door shall be placed a minimum of 16'-0" from the inside edge of the sidewalk, so as to provide one additional parking place per residence in the driveway. (See Street Improvement/Open Space Plan for garage setbacks.) Of course, there will also be the usual City-required enclosed garage.

INTENT:

To maximize the number of parking spaces available on the street; and to provide two off-street parking places per house. A 9' curb cut provides increased opportunity for street planting and the single car garage door allows for greater flexibility in building design.

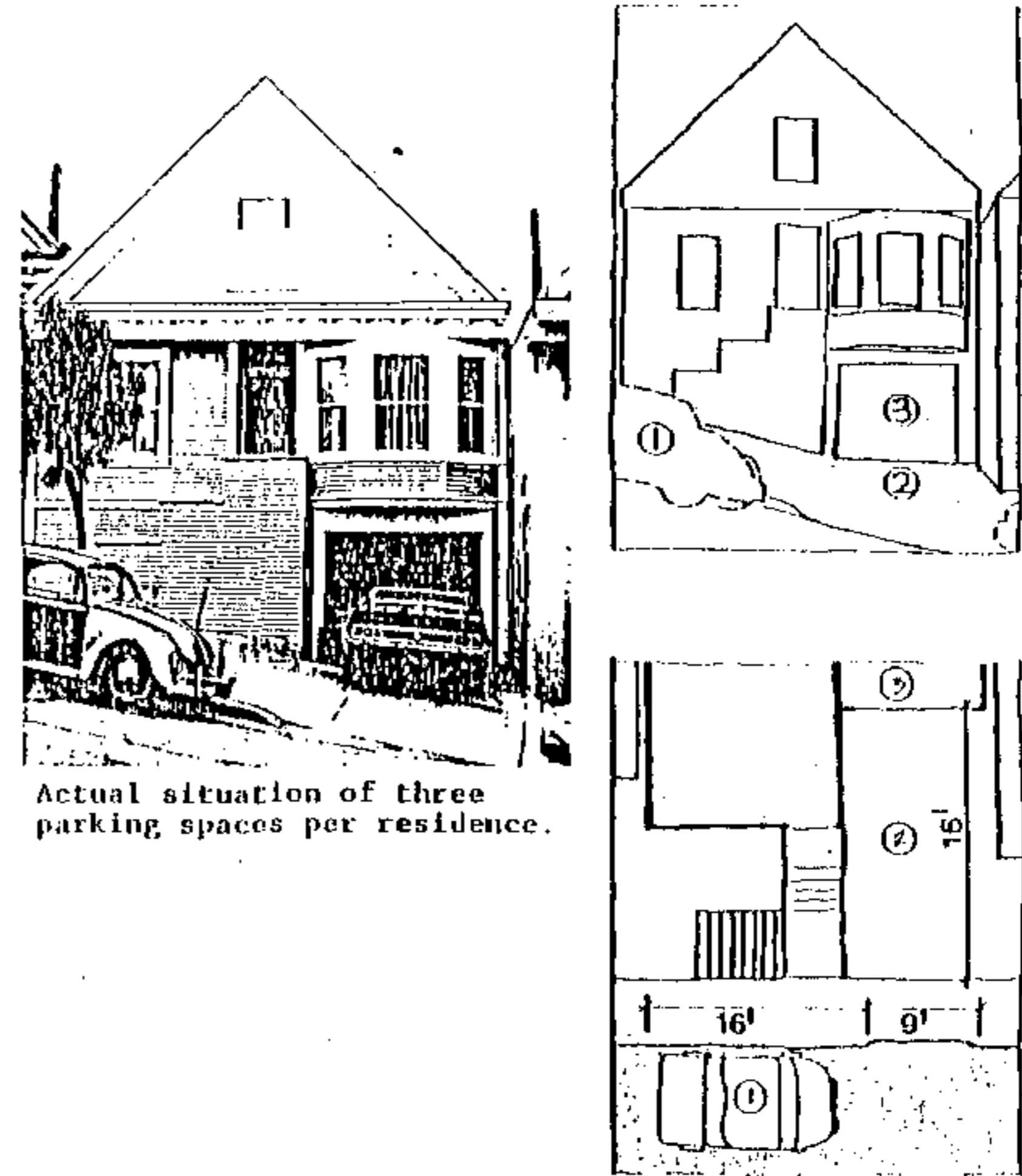

Single car entry: space for one car on street in front of each 25'-0" lot -- street parking maximized.



actual situation

Double car entry: no full on-street curb space -- street parking eliminated.

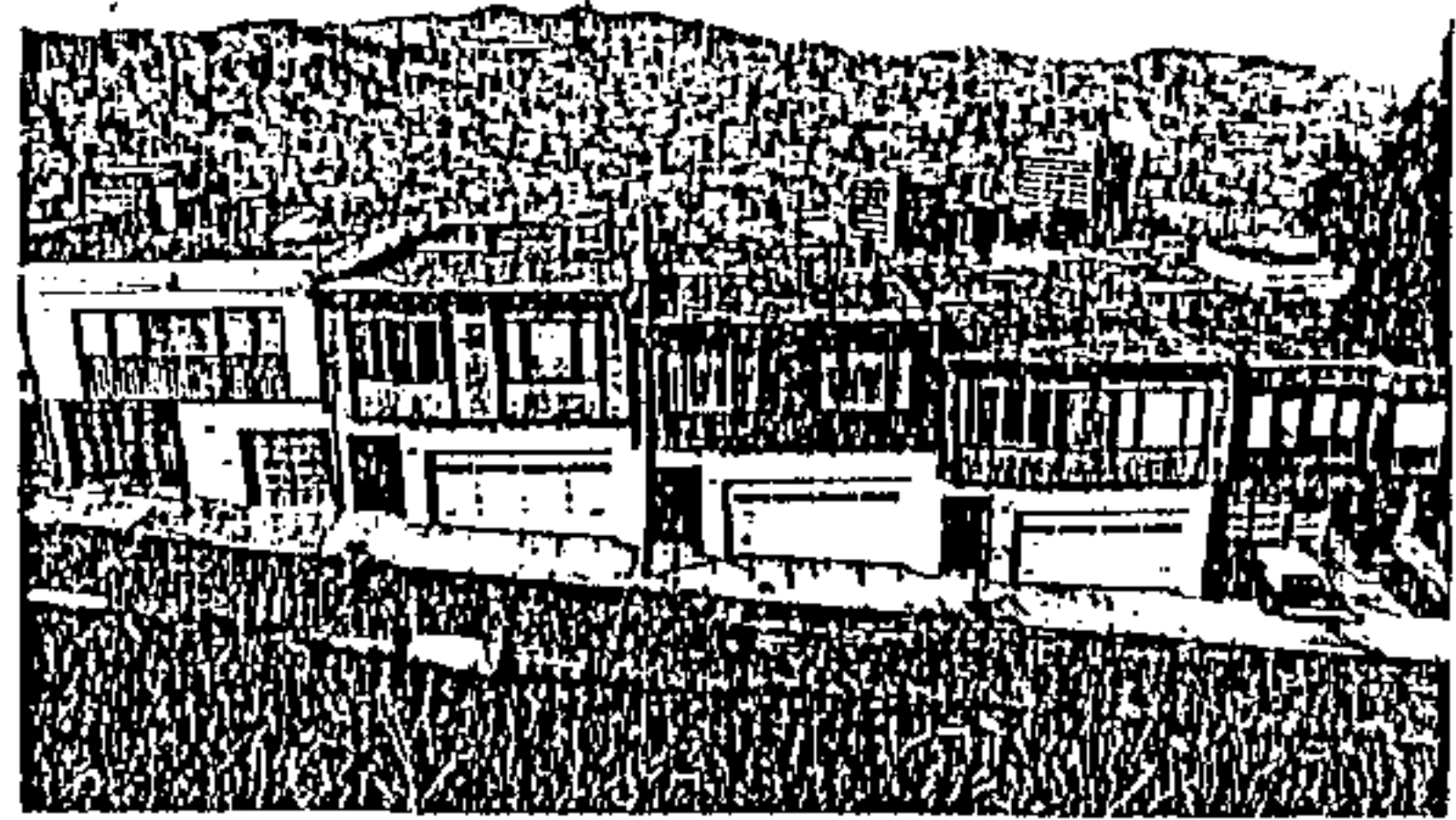

actual situation

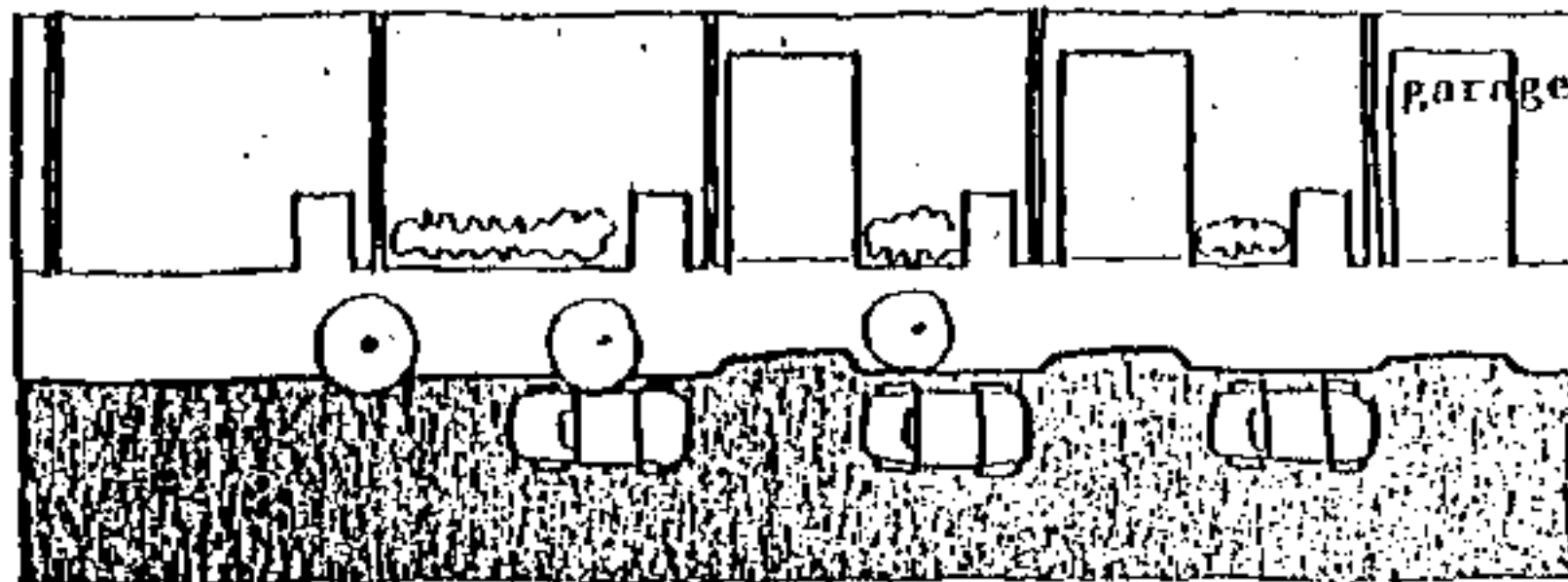

plan of scheme

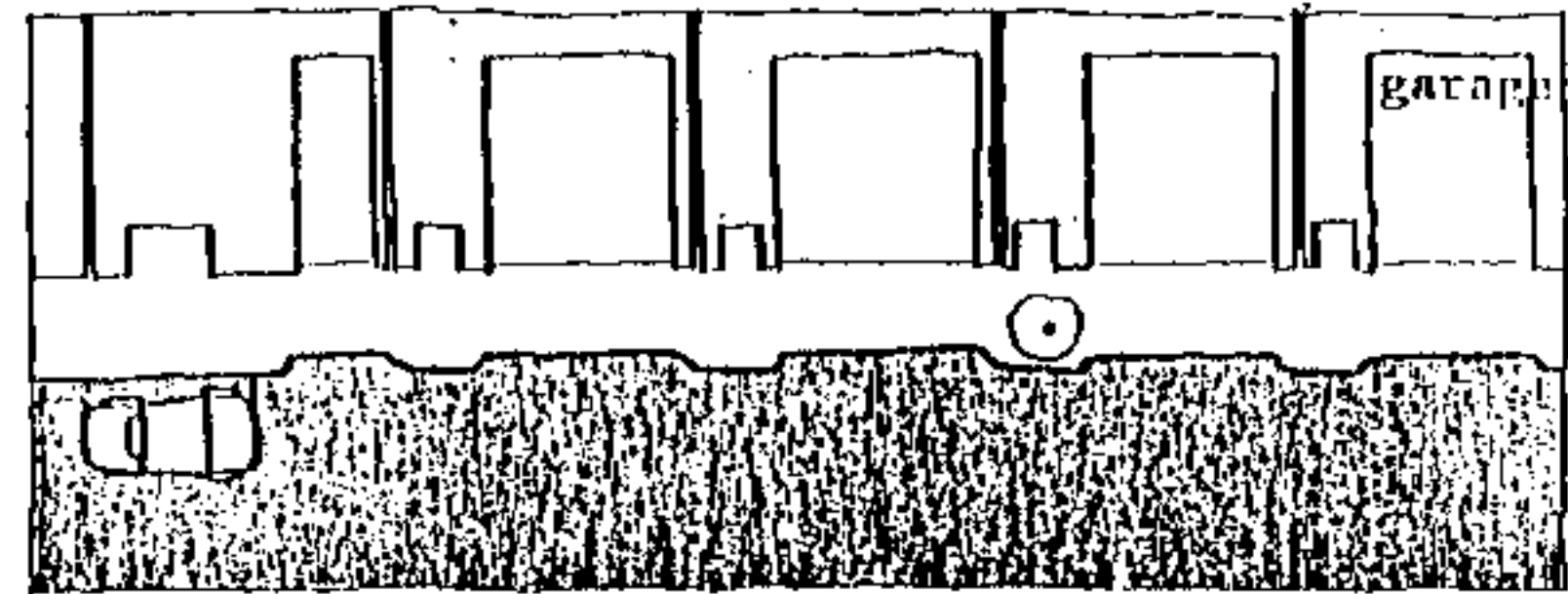

plan of scheme

LANDSCAPING / FRONT YARD SETBACKS / STREET TREES

It is recognized that landscaping and the inclusion of street trees in residential areas is one of the most important factors in providing an area with intimacy of scale and character.

LANDSCAPING

Greenery helps to provide privacy without barriers, soft edges in the built environment, and a reminder of our relationship to the earth. The fantastic geometry of biology combines well with the more rigid geometry of building forms. Landscaping can be used as a device for bringing color and texture into the urban scene. More functionally, if properly planned, it can serve to disguise unsightly foundation work and the like.

FRONT YARD SETBACKS

Front yard setbacks pave the way towards increased opportunities for landscaping and variety of entry approaches. With structures placed back from the property line, a feeling of openness is maintained and the access of light and air to the street is maximized. When a house is placed up to the sidewalk on sloped terrain, all sense of the topography of the lot is lost.

STREET TREES

"The livability, amenity and character of residential areas are greatly enhanced by trees, more so than by any other single element." (Fundamental Principles for Neighborhood Environment #1, The Urban Design Plan for the Comprehensive Plan of San Francisco, May 1971.) Street trees create rich textured patterns of light and reflection on the sidewalk, are pleasant to walk under, and provide places for birds to roost. They reflect the passage of time as they change with the seasons, connecting us to nature's timetable.



PROBLEM:

New construction which has no provision for landscaping at the front ignores the importance of greenery in enlivening the streetscape.

There presently exist no public trees on the street.

RULE:

Front Building Setbacks shall be required. They have been defined on a lot-by-lot basis and are listed below. These setbacks have been established by: 1) conforming with existing setbacks on adjacent or near-adjacent houses; 2) averaging when lot in question is between two existing structures; 3) providing for the use of existing foundation pads; and, 4) topographic considerations. (See Street Improvement/Open Space Plan.)

List of Minimum Front Yard Setbacks

Lots 4, 5, 6, 7, 8, 11	12'-0"
Lot 14	13'-0"
Lots 15, 17	6'-0"
Lot 20	14'-0"
Lot 41	13'-0"
Lot 43	11'-0"
Lots 48, 49, 50, 51, 53, 54, 56, 57, 58, 63, 64	9'-0"



Examples of buildings built up to the property line with little or no provision for front landscaping.

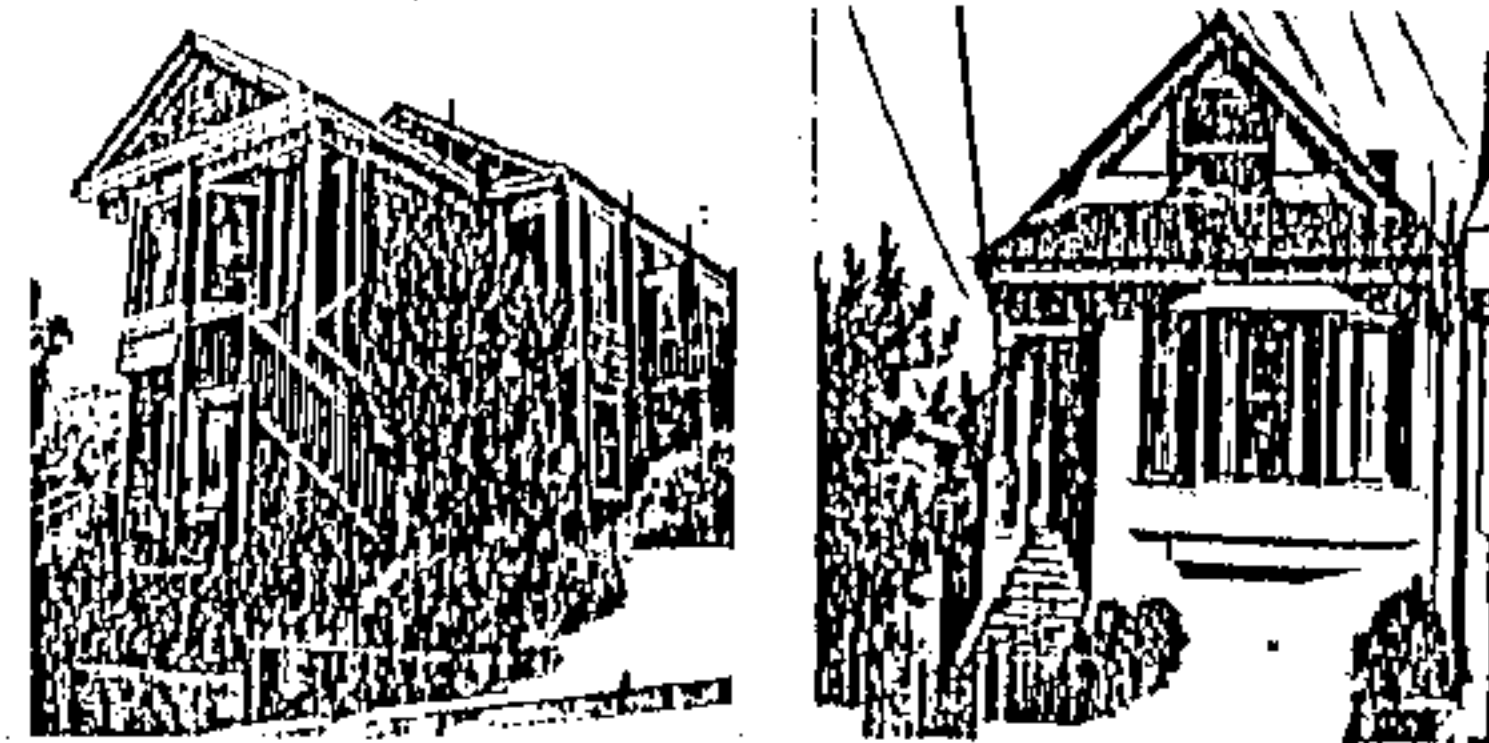

Examples of well-landscaped front yards

160
61 Block
away?

RULE:

50% of the Front Building Setback area (not including the driveway up to the garage) shall have provision for landscaping (i.e. trees, shrubs, flower beds, ground cover, vines, etc.)

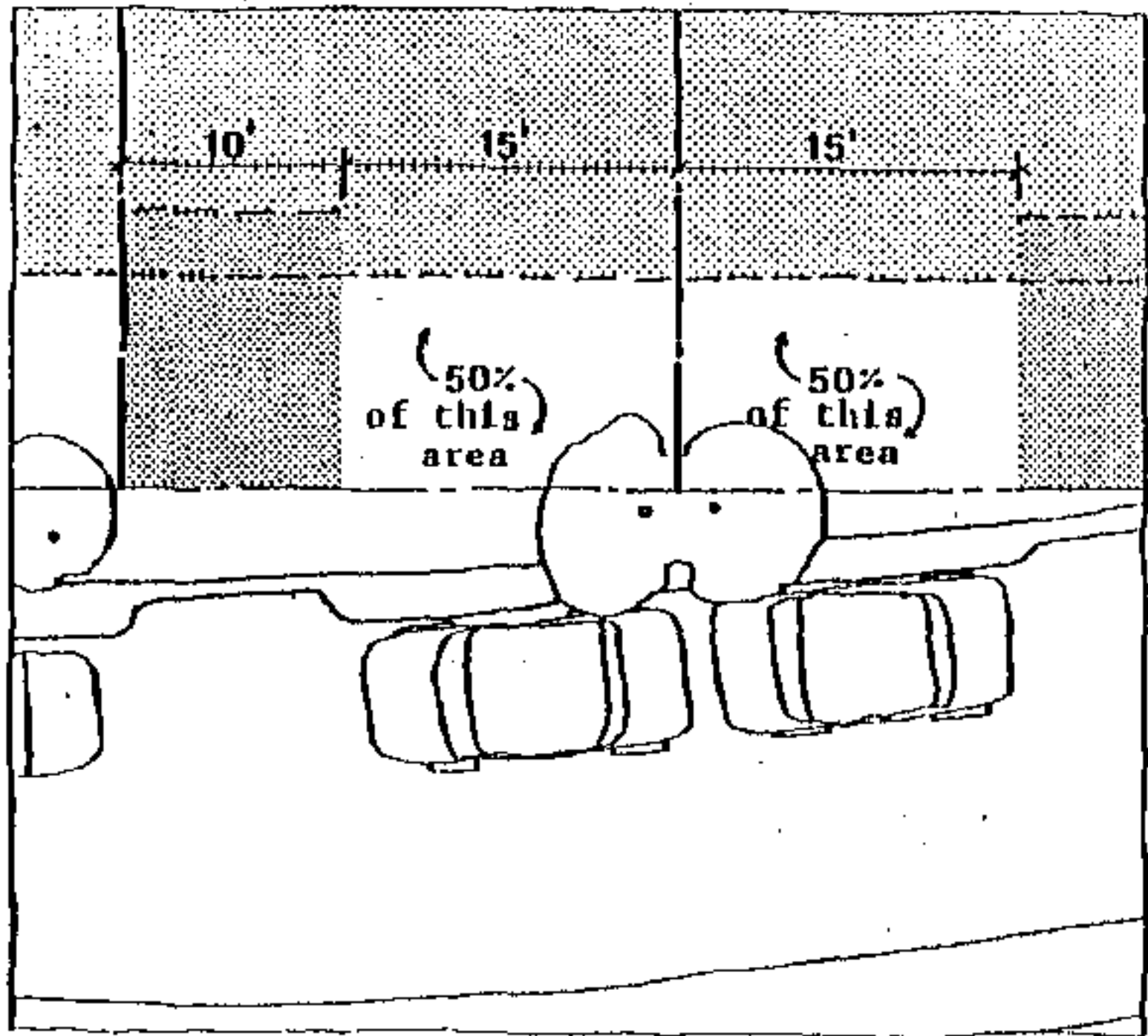

RULE:

One street tree shall be planted at the time of construction in front of each lot within the 40'-0" wide street right-of-way, and close to the front property line. (See Street Improvement/Open Space Plan for schematic placement of new street trees.) Trees shall be 15 gallon size and six appropriate trees are recommended below.

Recommended Street Trees:

1) *Cerantonia siliqua* (Carob)

Round, dense form. Dark green foliage. Rough brown bark. 30'-40'. Must be protected from ocean winds. Sun or shade. Moderately fast grower. Needs ample root space.

2) *Ligustrum lucidum* (Glossy Privet)

Round headed. Glossy green foliage. Whitish flowers in clusters. 20'-30'. Sun or shade. Some protection. Seacoast conditions. Loam soil with drainage. Drought tolerant. Withstands shearing. Fruits in warm areas.

3) *Maytenus boaria* (Mayten tree)

Narrow or spreading form. Dense, glossy green small leaves. Graceful. 20'-25'. Sun or part shade. Moist, fertile soil. Partial protection. Tolerates fair amount of wind and fog. Pendulous growth. May need pruning. Spray for aphids.

4) *Metrosideros excelsa* (New Zealand Christmas Tree)

Rounding form. Dark green, leathery leaves. Dark red flowers 25'-35'. Sun or part shade. Fertile, sandy loam. Moisture. Growing space. Mild coastal conditions. Wind, fog and salt tolerant. Prune to open up. Not subject to insects or disease.

5) *Pittosporum undulatum* (Victorian Box)

Rounding, dense form. Bright green foliage. White, fragrant flowers. 20'-30'. Sun or part shade. Sandy loam. Drainage. Some protection. Tolerates seacoast conditions. Prune to develop height and to thin out.

6) *Pyrus kawakami* (Evergreen Pear)

Broad, spreading, glossy green foliage. White flowers, willow drooping branches. 15'-20'. Sunny, warm location. Loam soil with moisture. Protection. Stake to support. Prune to train and shape. Variety of soils okay.



ENTRY TREATMENT

"Entrances create a transition between the 'outside' -- the public world -- and some less public inner world.

"...What matters most is that the transition exists as an actual physical place, between the outside and the inside, and that the view, and sounds, and light, and surface which you walk on change as you pass through this place. It is the physical changes ... which create the transition." (112 Entrance Transition, A Pattern Language, Christopher Alexander, Sara Ishikawa, Murray Silverstein: Oxford University Press 1977).

PROBLEM:

We are concerned with the way in which entries are handled. There are many approaches to entries;

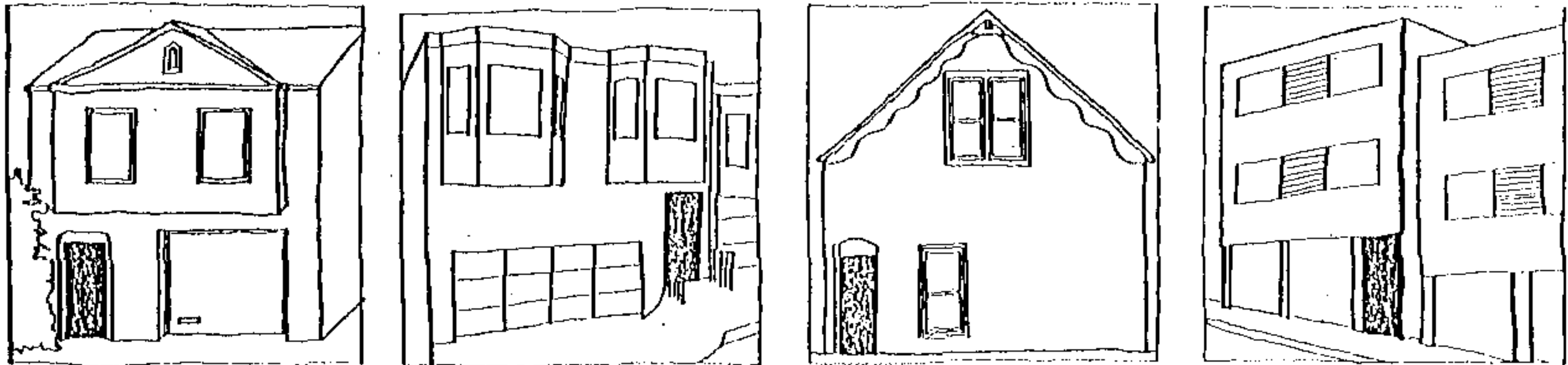

These entries all have the same problem: they are basically holes in the wall. There is no transition place; landscaping is avoided; and no special treatment has been provided at the threshold.

however, they can basically be broken down into two categories: those which are essentially holes in the wall of the facade and those which are separated from the street by some sort of intermediary transition space. All too often in new construction, hole-in-the-wall doorways are resorted to.

RULE:

Make the entry of the house something special -- a celebration -- more than just a front door. Create a transition between the street and the doorway. Give special attention to the treatment of the framing of the opening itself.

The following examples and their descriptions illustrate our intent.

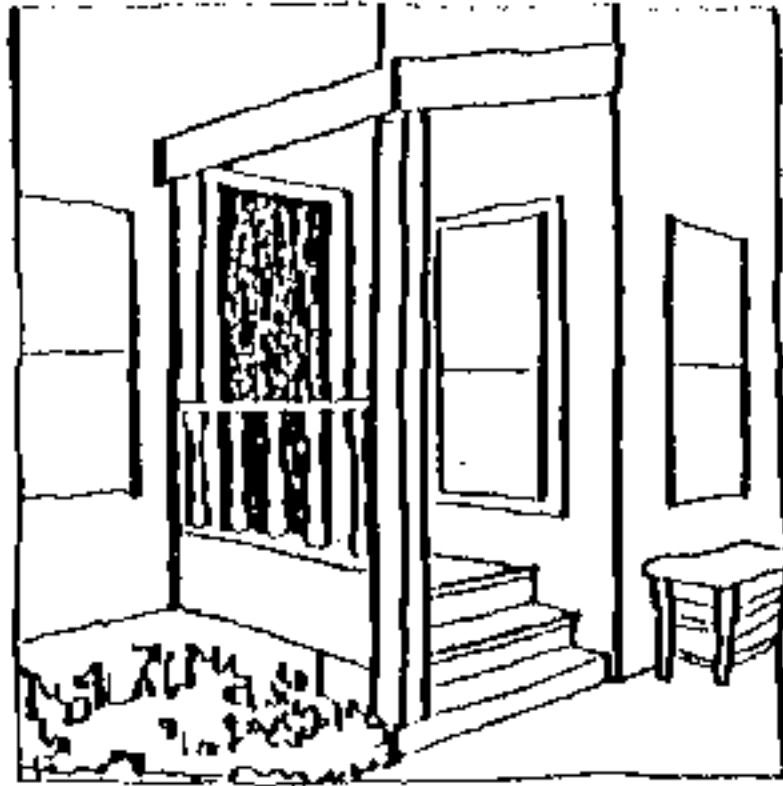

(1) This entry is highlighted with a canopy overhead and an embellished handrail. Despite the fact that one essentially enters on grade, a forced change of level takes notice of the importance of its function. A touch of landscape softens the approach. A sitting place by the entry harks back to a time of stoops and street watching. The difference between the brightness of unfiltered sunlight and the subdued light of the interior is bridged by the lowered light level under the overhang.

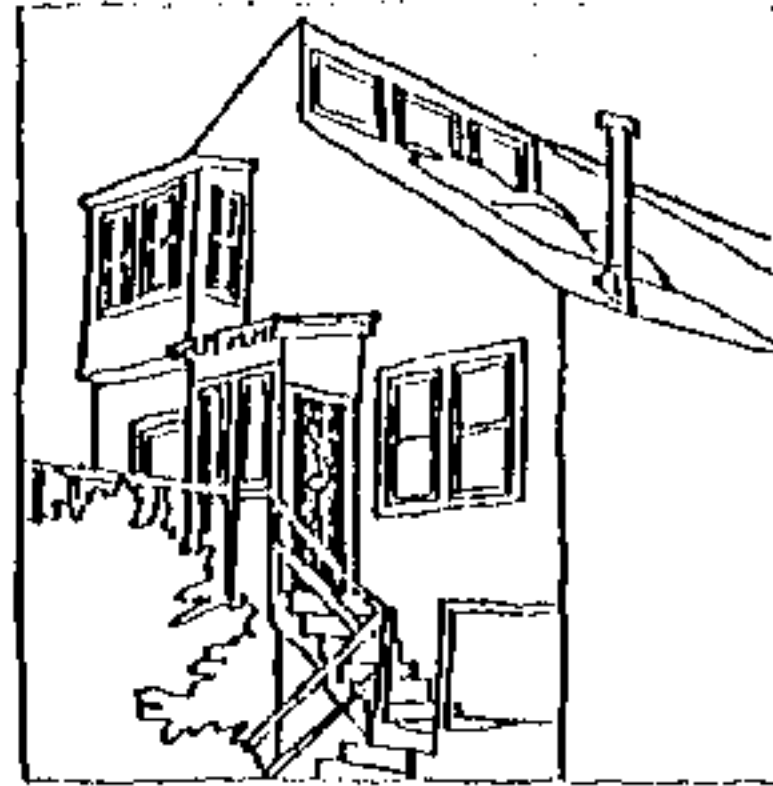

(2) This entry combines level changes, directional changes and textural changes, in the form of varied foliage, to make its statement. The front door is set in a lighted vestibule that is welcoming. The window adjacent is a friendly indicator to the visitor of what is to come as it gives the occupants a sneak preview of what they'll find on their doorstep.

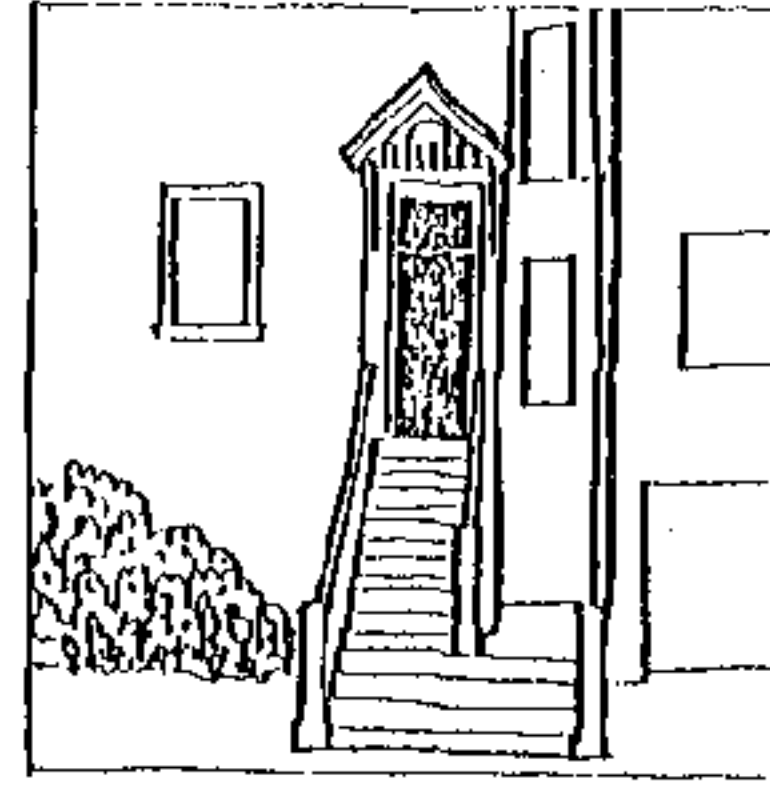

(3) This entry comes straight off the street and yet avoids merely being a hole in the wall by rising to accentuate the transition and by being framed and trimmed out in a special way. In addition, the double width steps at the base unify the building's entry with its sideyard access.

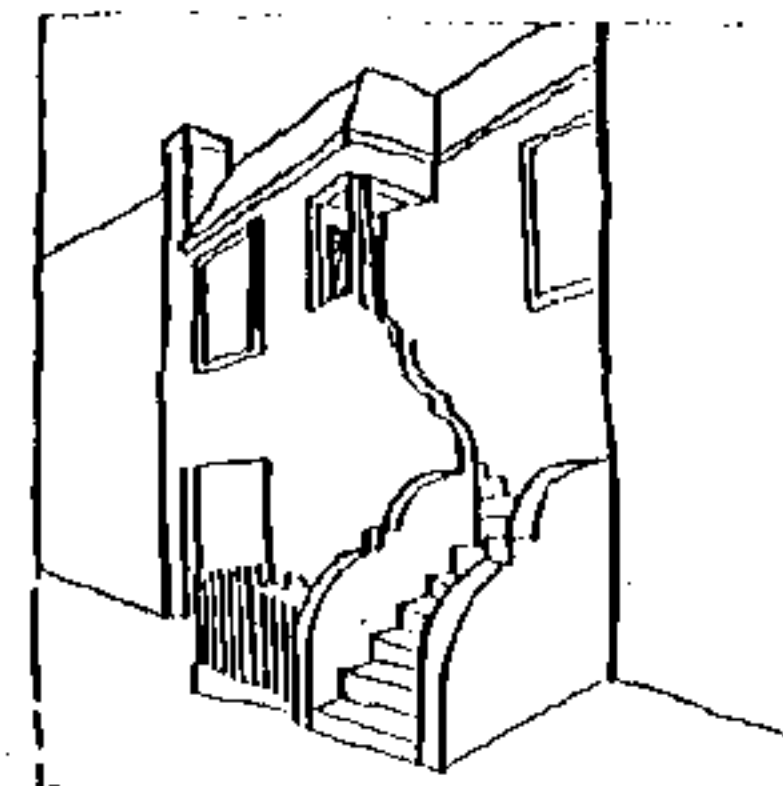

(4) This entryway incorporates many positive features: change of level, change of direction, change of texture and light. Perhaps most significant, however, in this example is the simple but whimsical treatment given to the structural elements used to frame the stairway. Everything points up the unique function of the entry in the hierarchy of the building.

FENCE TREATMENT:

For a person on the street it is far more pleasant to be allowed a glimpse of the space beyond a fence or wall than to be confronted with a solid barrier.

RULE:

Fences or walls which enclose a lot or a portion of a lot, which run parallel to the property line on the street side, and are not structural portions of the building or the stair leading to it, shall not be completely solid at eye level.

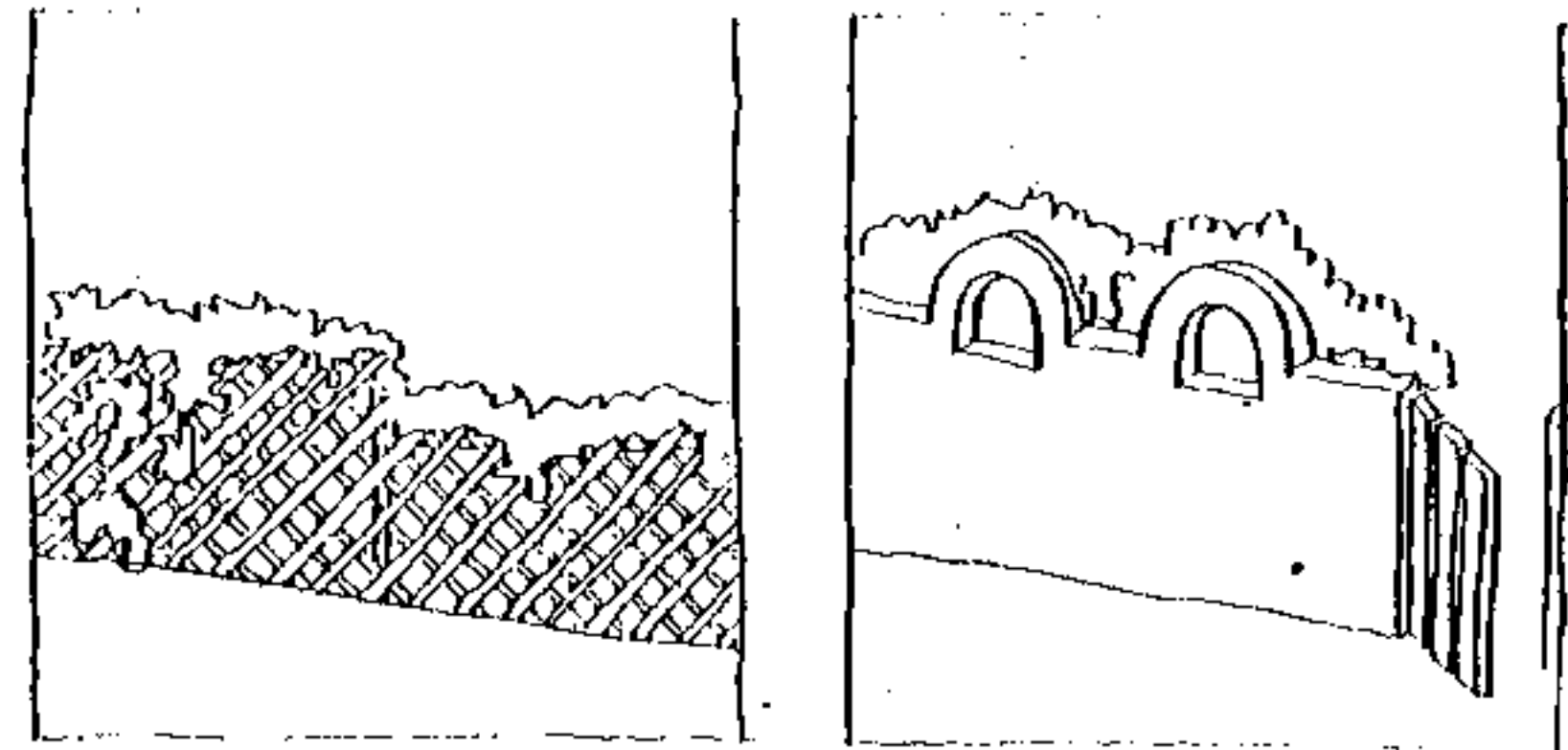

Suggestions for fence treatments



Fences which meet guideline standards

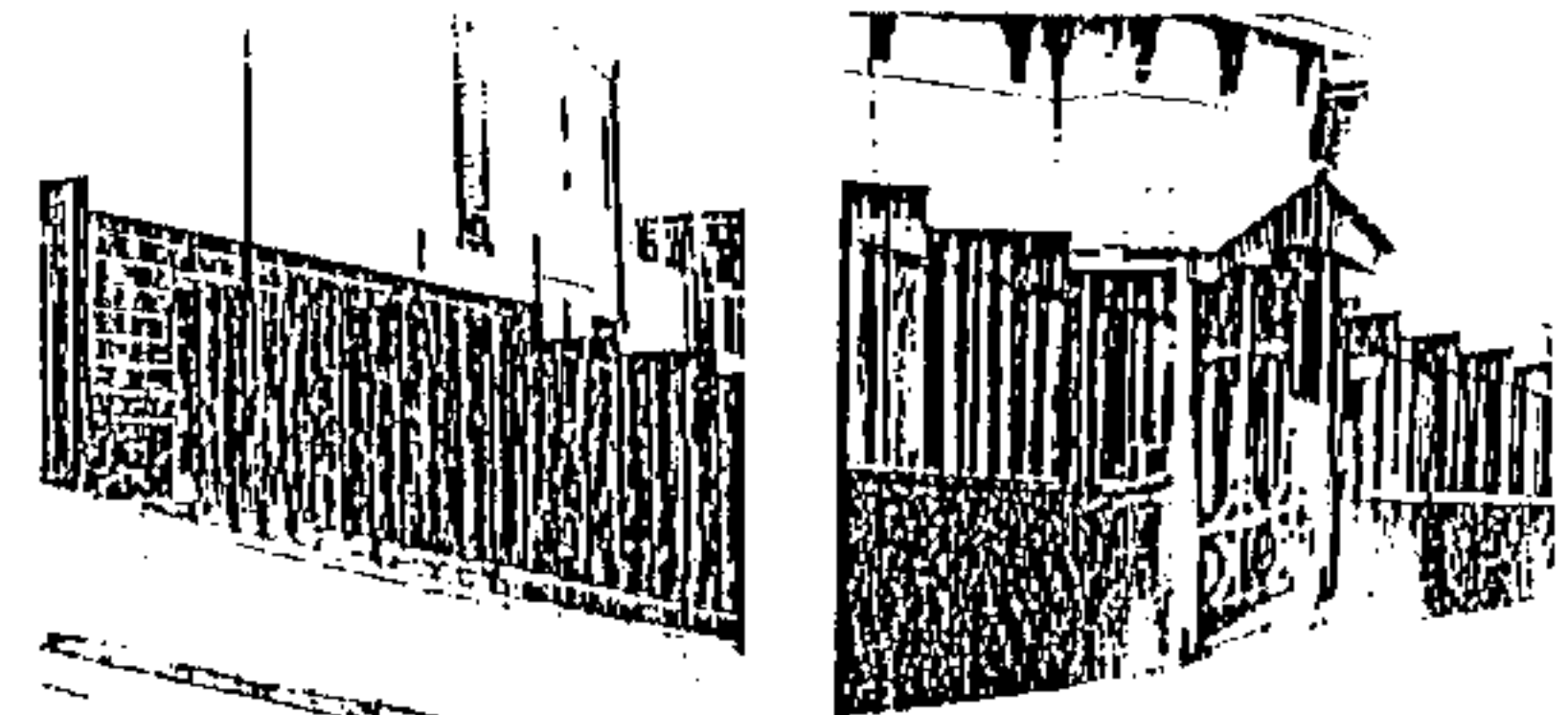

Fences which do not meet guideline standards

BUILDING BULK & ARCHITECTURAL MASSING

It has been recognized by the City of San Francisco, as well as by the residents of Bernal Heights, that the character of new construction is destined to have a long term effect on the nature of our city and its neighborhoods. The Urban Design Element of the Comprehensive Plan for San Francisco supposedly includes design principles, which provide guidance to potential developers, in order to assure that new development be compatible with the delicate scale and character of the existing houses in hillside residential areas. If planning principles are to be judged by the success of the products, those set forth thus far have failed.

On Bernal Heights there are some 350 open lots, and in the last few years, development pressure has skyrocketed. The new "vernacular form" is the maximum-building-envelope-shoebox. The box presents an image more reminiscent of apartment units than of a house form. It is a solution without a context, which isolates itself from its setting by not acknowledging its neighbors, its views, its orientation towards light and air paths. It is a non-specific plan which developers scatter around the city wherever open lots occur.

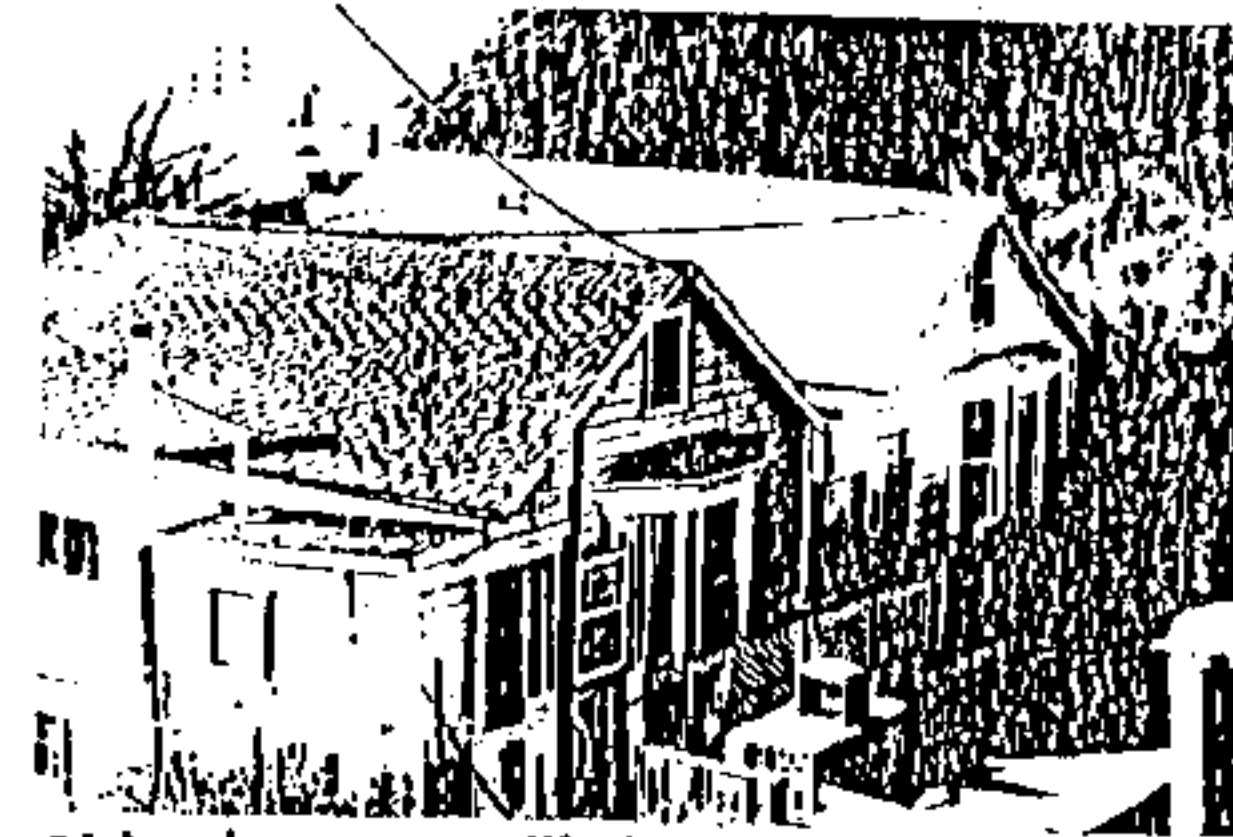

Older houses on Elsie Street



Newer "shoebox" houses on Elsie Street

When the box first appeared, the dull street-scape that it presented drew a lot of criticism. People called for a form more in keeping with the spirit of San Francisco's architecture. The bays and miniscule balconies which were tacked on have proven to be no more than band-aid solutions. The dressed-up box has not fooled anyone. Its token accoutrements, rather than being a part of the organic whole, are elements that deny the overall integrity of the building.

PROBLEM:

On the 100 block of Elsie Street, most of the remaining open lots are steeply sloping (see attached site profiles). Consequently, the main problem here is one of heights and architectural massing.

"The downhill slopes are particularly problematic because most house designs provide living space only above the street plane, with void space below. This void space is either open, with a stilt structure supporting the house, or closed, with blank walls to the ground. Either situation is unsightly and wasteful. These void spaces often comprise more cubic footage than the residence itself, thereby doubling its apparent bulk. Older structures tend to have much smaller void spaces under them and therefore much less bulk. New residences should have living spaces as close to the ground as possible. This looks better from below, reduces bulk and makes rear yards more accessible."

("Residential Development On or Near the Top of Hills," from Policies from San Francisco Department of City Planning Documents.)

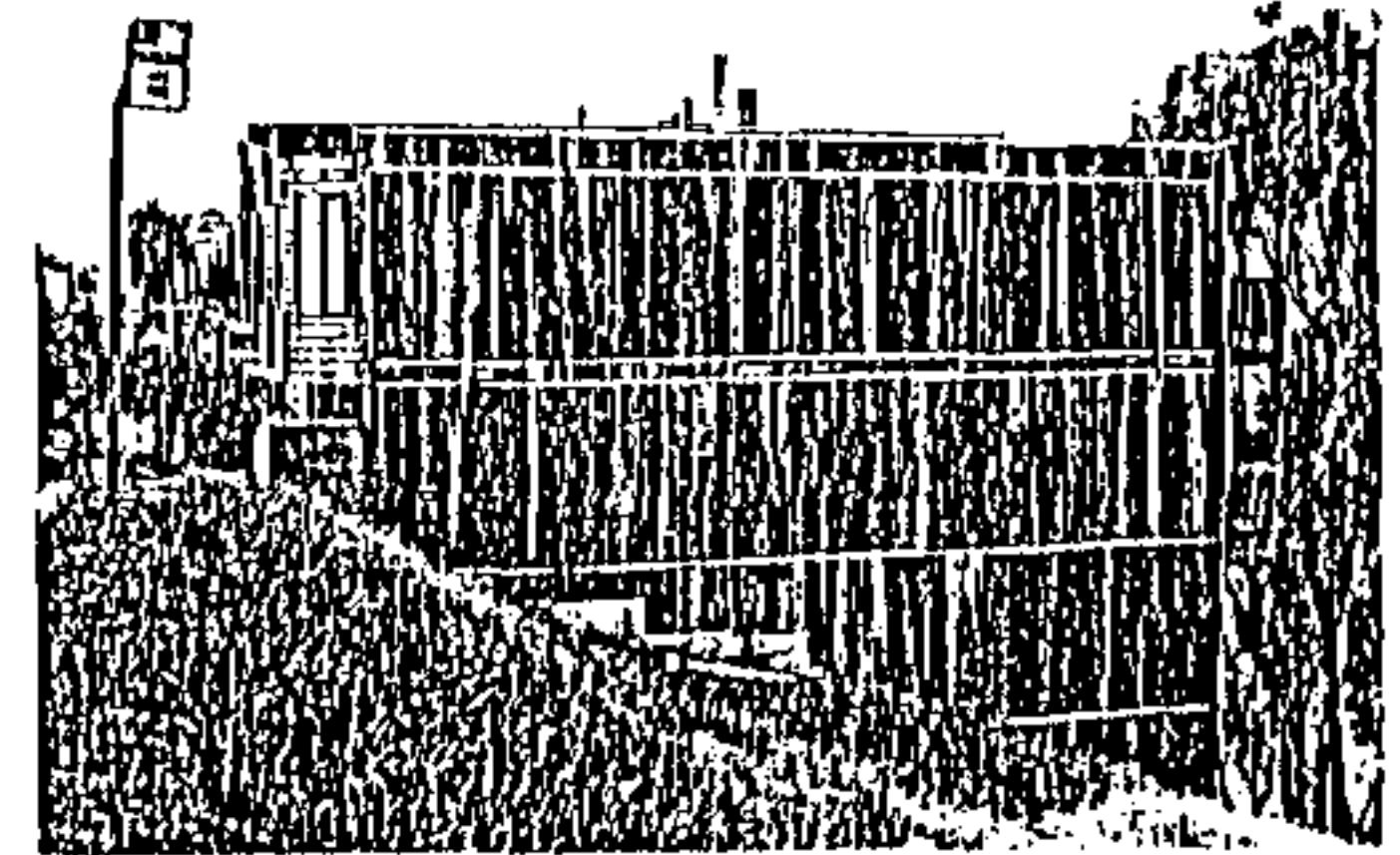

Dressed up box on Elsie St.. Note proportions of token bays and tacked-on balconies at rear which are too small to be functional. Imagine how any building placed next to it would be overpowered by its bulk.

Present height restrictions in San Francisco do not take into account the sloped conditions which exist throughout the City. By merely setting a 35'-0" height limit from street grade, rear

facades on the downslopes reach lowering proportions when a maximum envelope is constructed. Because this has happened in the recent past, the residents downhill from Elsie Street on Winfield Street fear that a great wall will appear, cutting off views, sunlight and air from their backyards if present construction practices continue.

The massing problem is one of relating a building to its topography. Unless the private open spaces (front, side and rear yards) surrounding a house are easily accessible from prime living areas they tend not to be used. If a building does not step with the slope it loses its relationship to the ground.

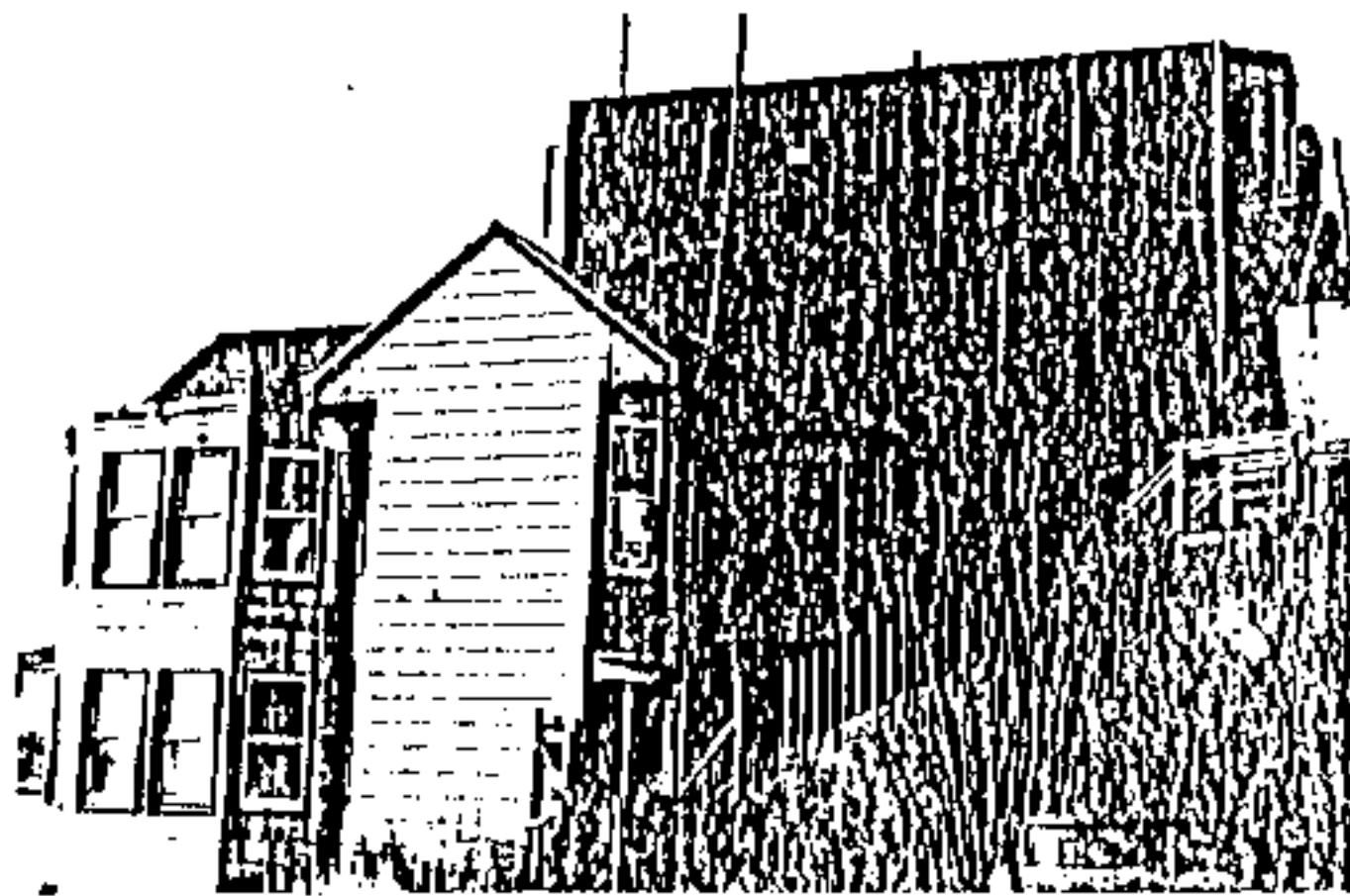

Towering rear elevation -- note dwarfed backyards of Winfield St. houses at bottom left.

The new juxtaposed against the old should blend better than this

Most houses in the Elsie Street Neighborhood are two stories tall and exhibit strongly individualized house forms. Because of current interior space requirements and a mandatory covered garage, buildings which are at least in part three stories are anticipated. The massing problem for prospective builders is to develop shapes which stack in such a way that the new meld with the existing when they occur side by side.

INTENT:

Our objectives in the Building Bulk Guideline are neatly summed up in already existing City Planning policies. To quote from the Urban Design Element of the Master Plan, our intent is to:

1. Minimize the blockage of morning sun from adjacent downhill properties;
2. Lower the first level of occupancy to a level enabling ready access to rear yard open space;
3. Deter the possibilities of visually dominant buildings with blank and uninteresting exteriors which do not relate well to surrounding development;
4. Promote harmony in the visual relationships and transitions between new and older buildings; and,
5. Encourage the construction of buildings which meet the ground and reflect the slope of the hill.

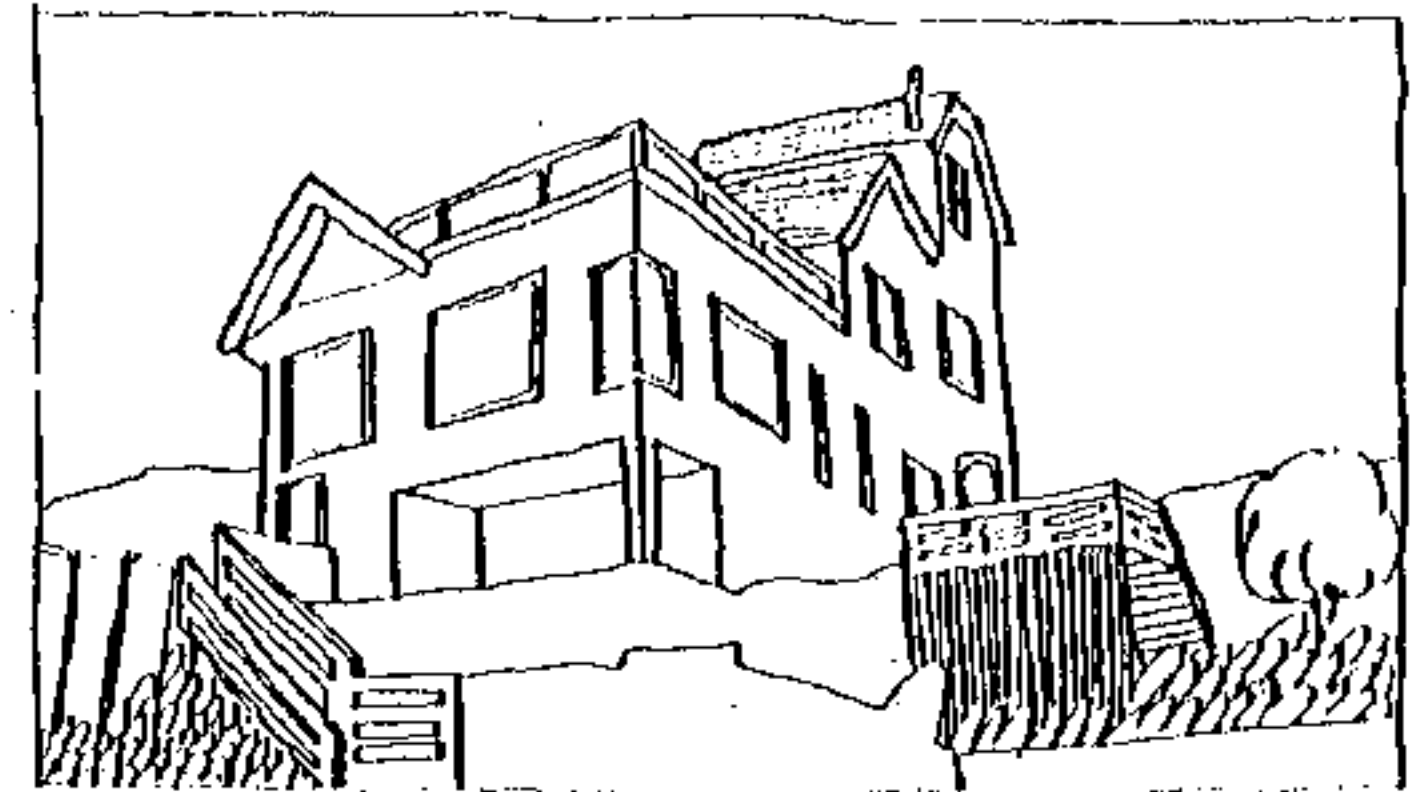

Building on Bonview St. -- stepping up the slope.

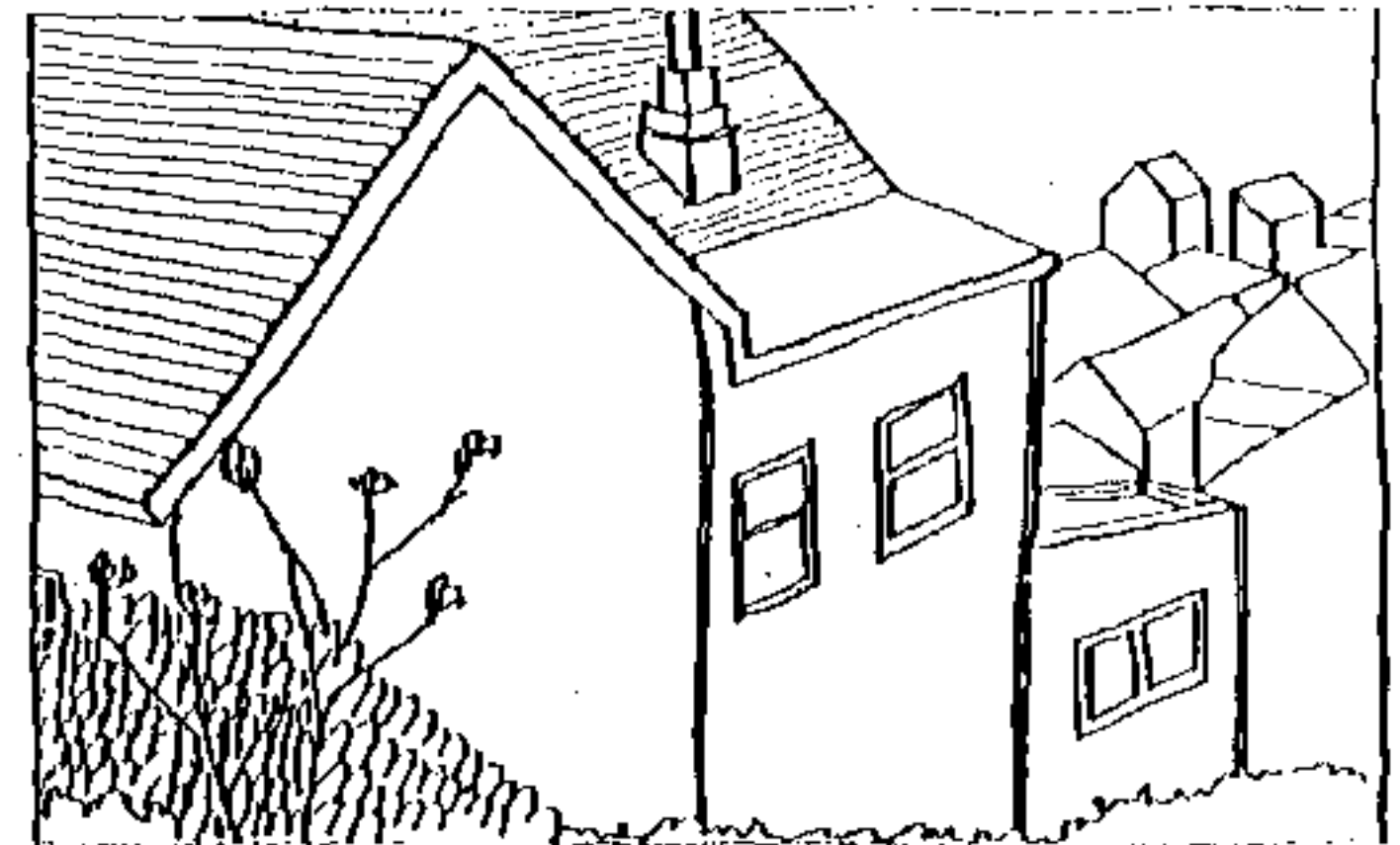

Building on Elsie St. -- stepping down the slope.

STRATEGY:

- 1) Step the building with the slope.
- 2) Break up the overall massing into articulated architectural pieces.
- 3) Break up solid plane of the facade.
- 4) Require at least a partial 4'-0" sideyard on one side of the lot (see Sideyard Design Guideline.).
- 5) Diminish height of the rear portion of the building.
- 6) Require pitched or usable flat roofs (See Roof Design Guideline.).

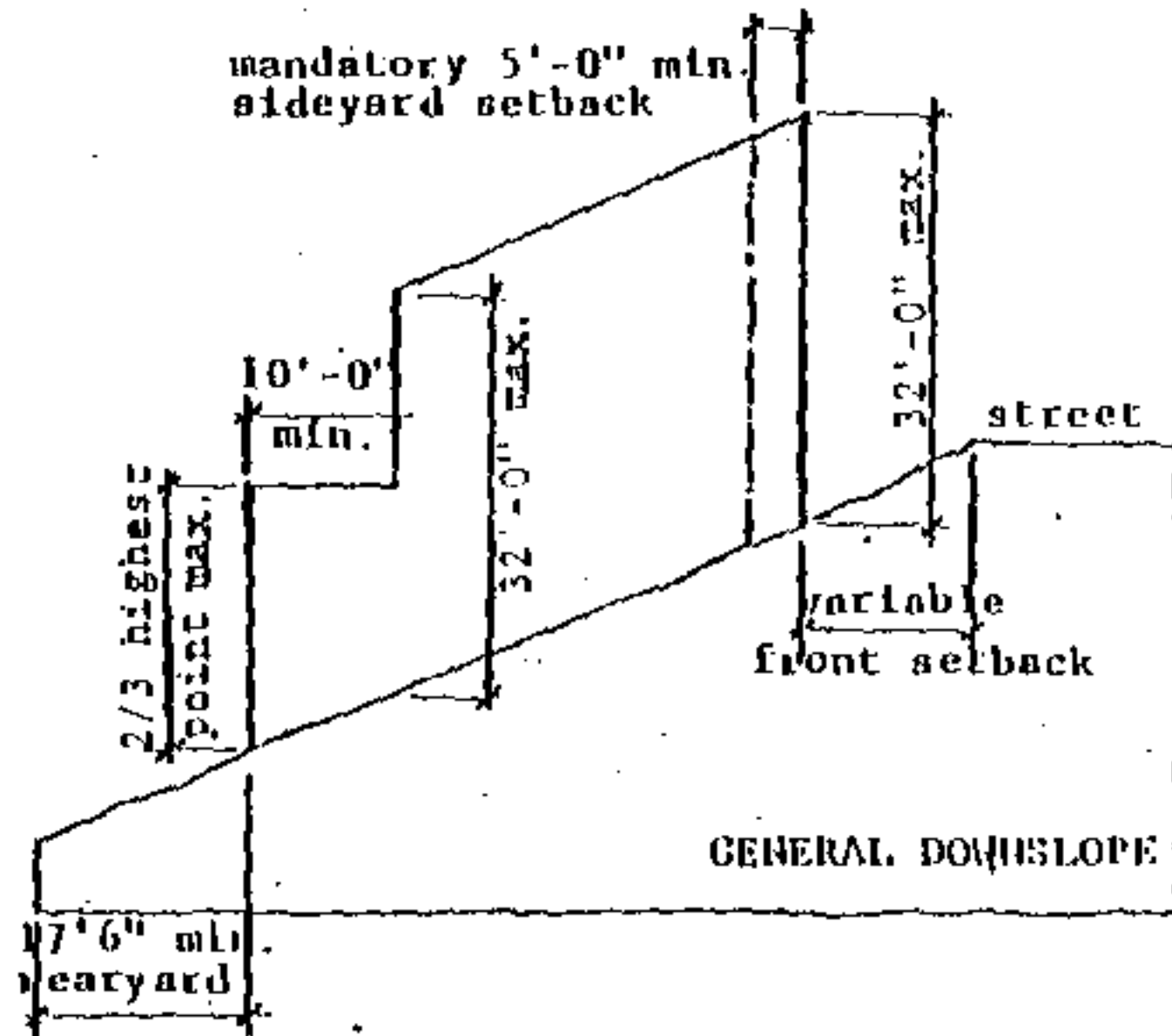

RULE:

Step the building with the slope.

Building shall not exceed 32'-0" from any point on natural grade. This height shall be measured to the average height of a pitched roof or to the highest point of a flat roof.

In addition, no point of the last 10'-0" of depth of the building may exceed 2/3 the height of the highest point of the structure. Highest point, once again, is defined as the average height of the pitch on a sloped roof or the highest point of a flat roof.

At the rear, a minimum 17'-6" rear yard is required.

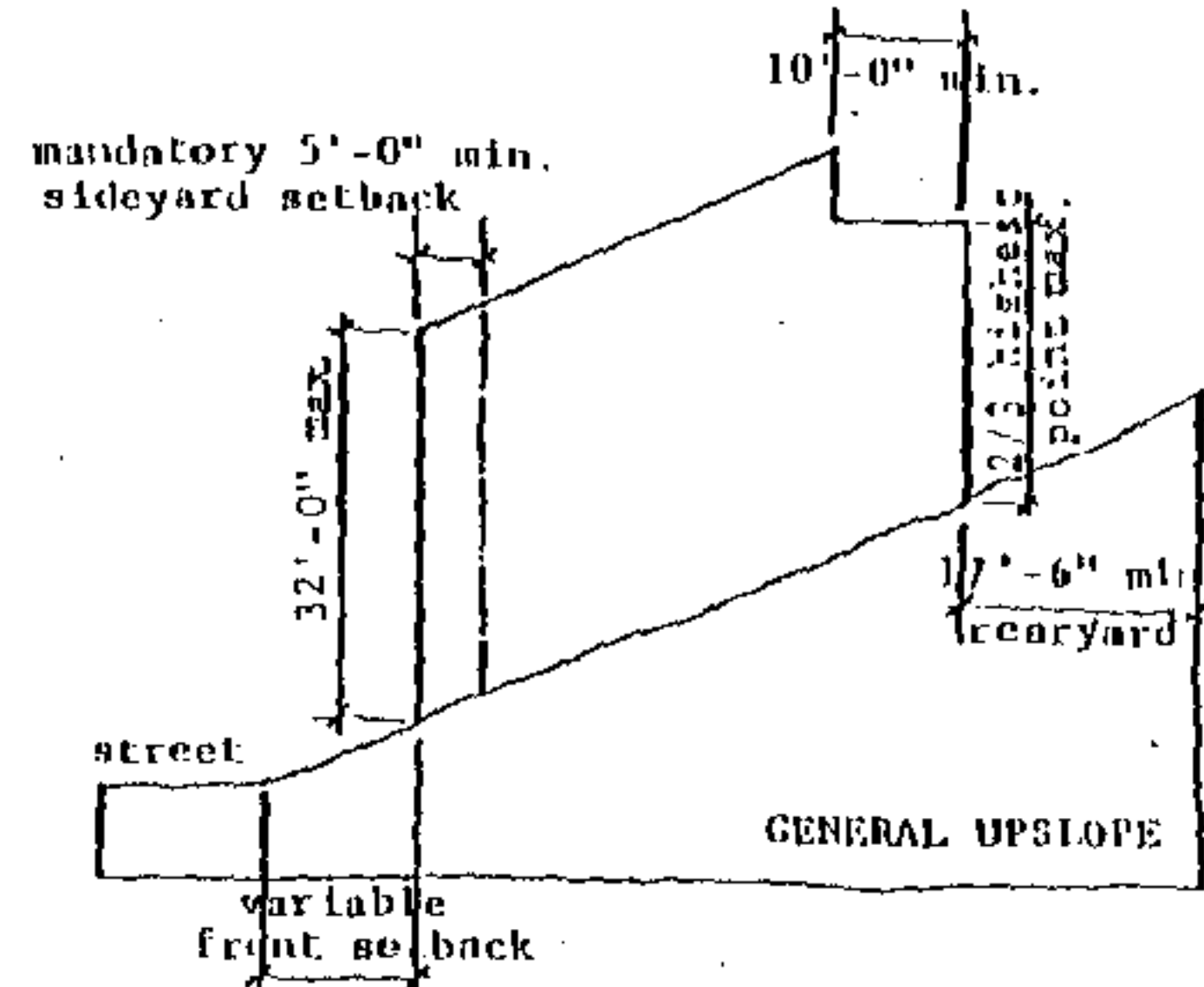

As with all of these guidelines, this one is dependent upon the implementation of all the others. Should there be amendments, particularly to the front and rear setback rules, these height limits would have to be revised.

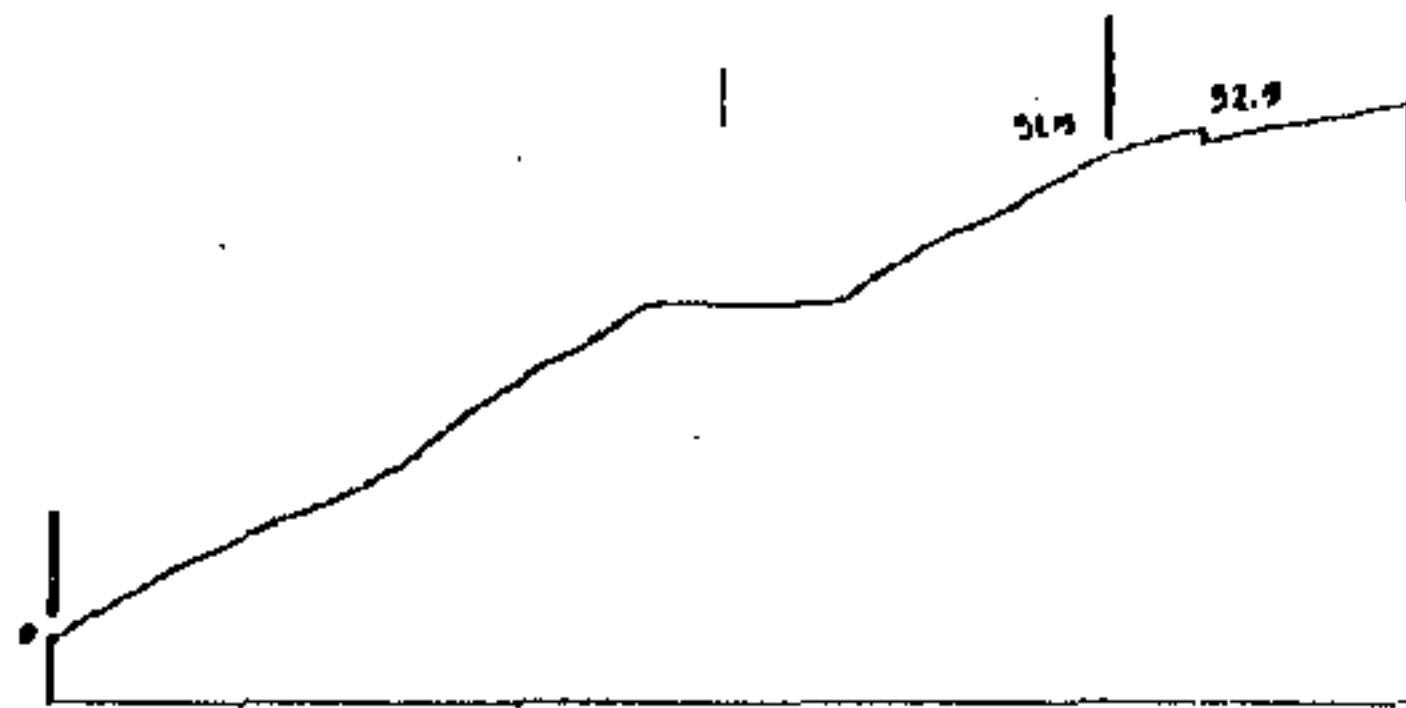

MICHAEL'S LOTS WEST

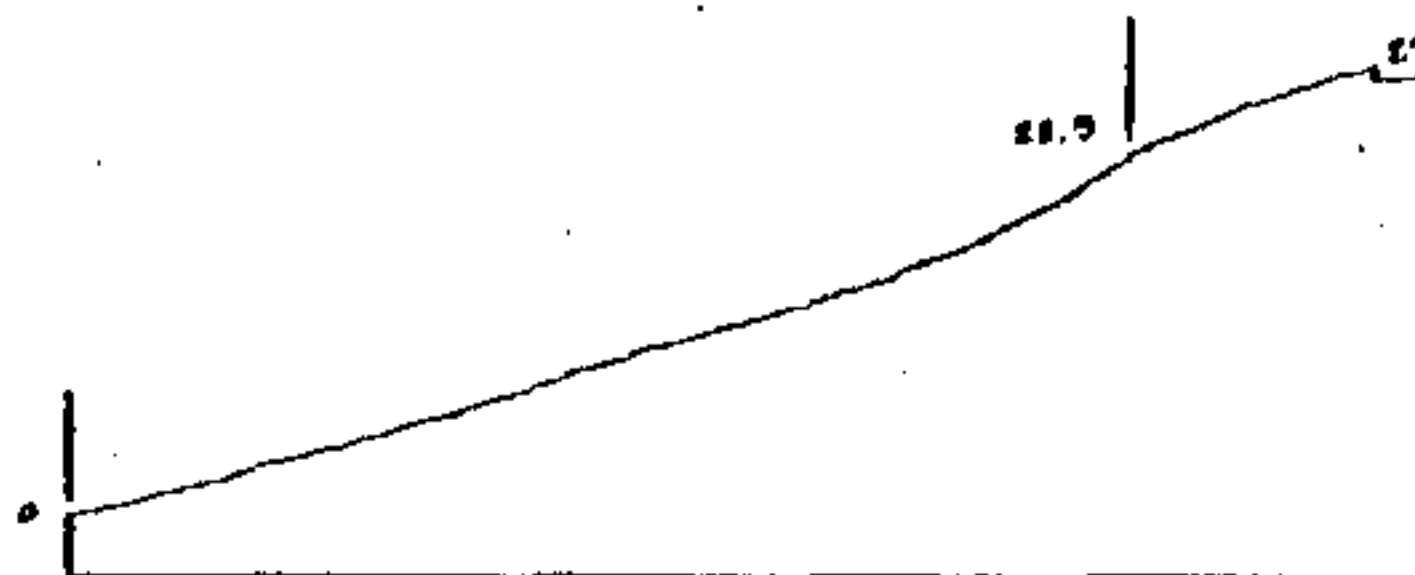

VALLEY LOTS WEST

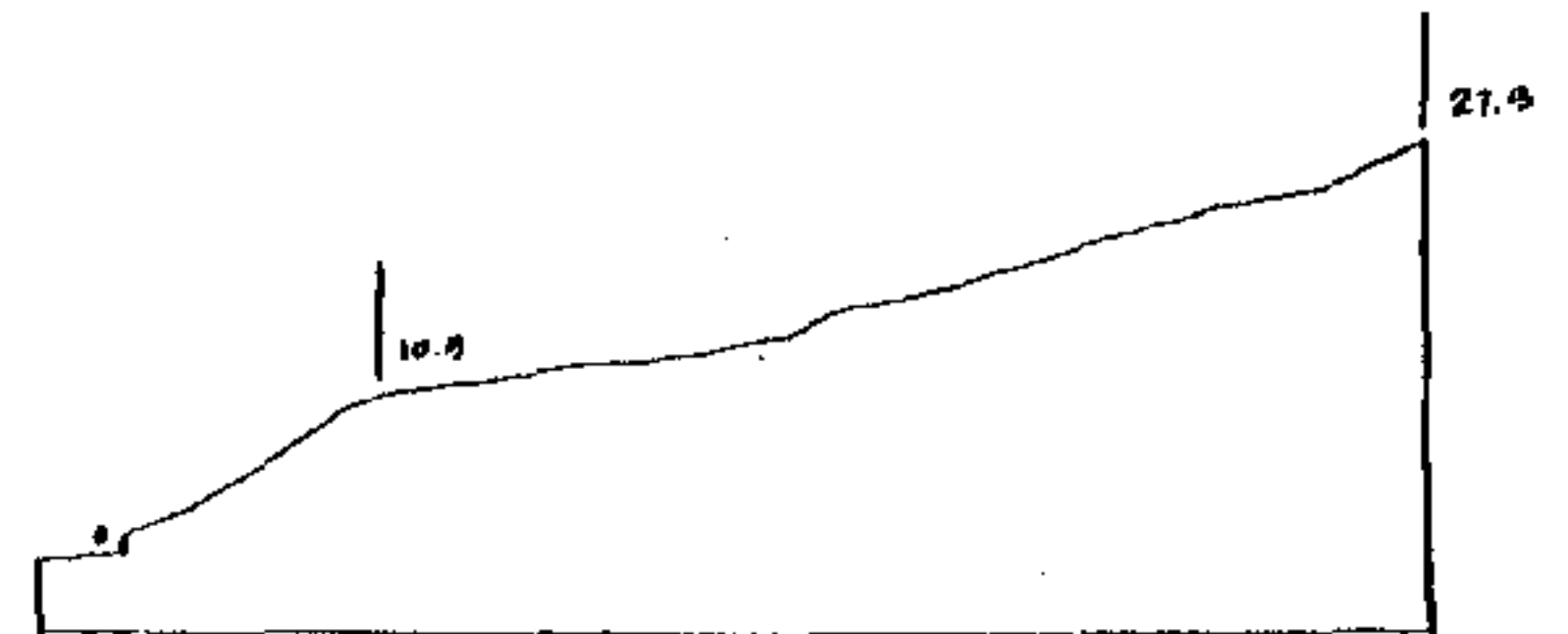

HIGH LOTS EAST

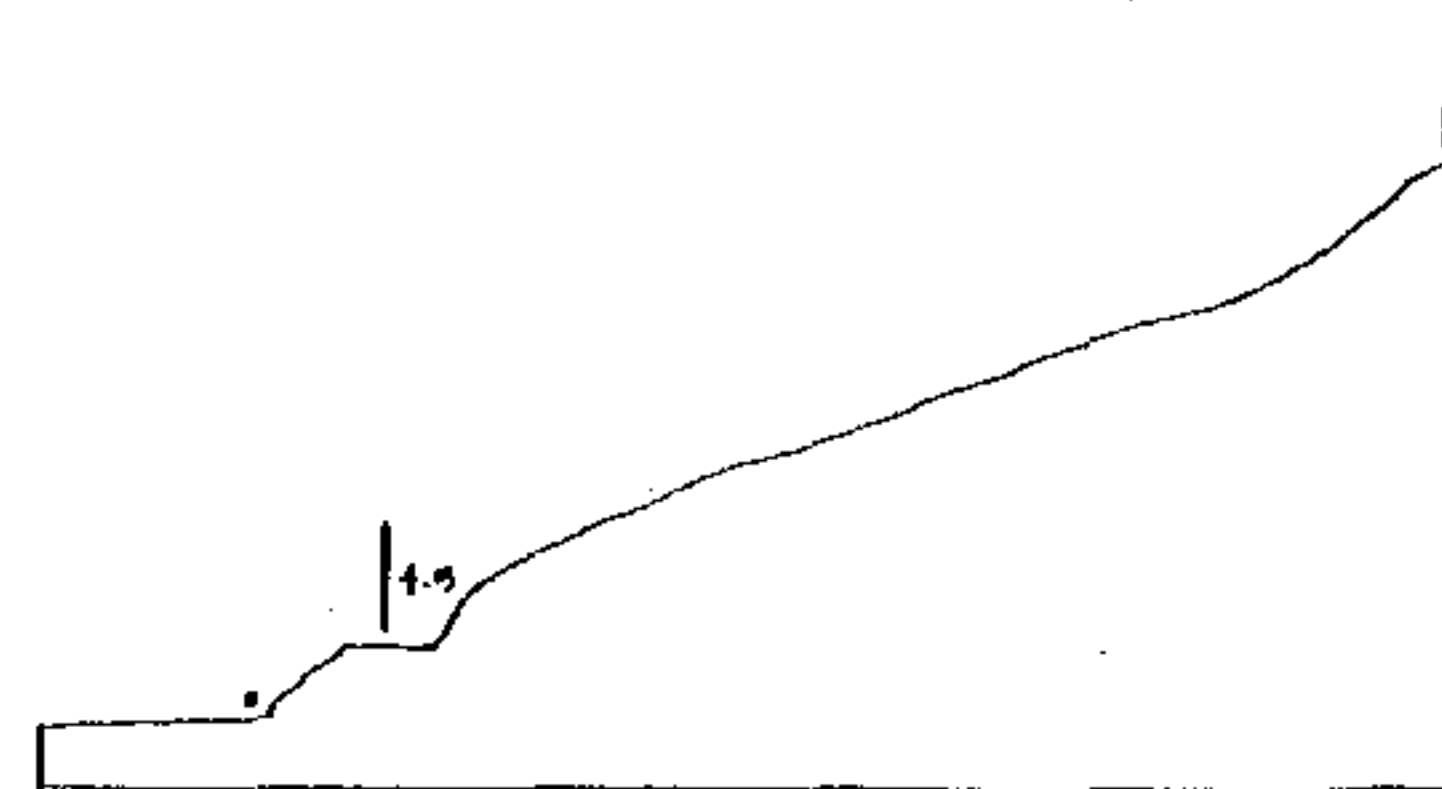

VALLEY LOTS EAST

SITE PROFILES

SIDEYARDS

After a long study of the pros and cons of requiring a sideyard on one side of the lot versus building lot line to lot line, it was determined that the inclusion of a sideyard is an essential ingredient in reaching our design objectives.

Our decision to go with sideyards is also consistent with our interest in insuring that new construction respect the existing scale and character of the neighborhood.

INTENT:

To help reduce the building bulk:

1. by breaking up the solid-wall effect on the street; and,
2. by providing increased opportunities for architectural articulation.

To provide access to rear yards:

3. for firefighters; and,
4. for garden work, children with muddy feet, and the like.

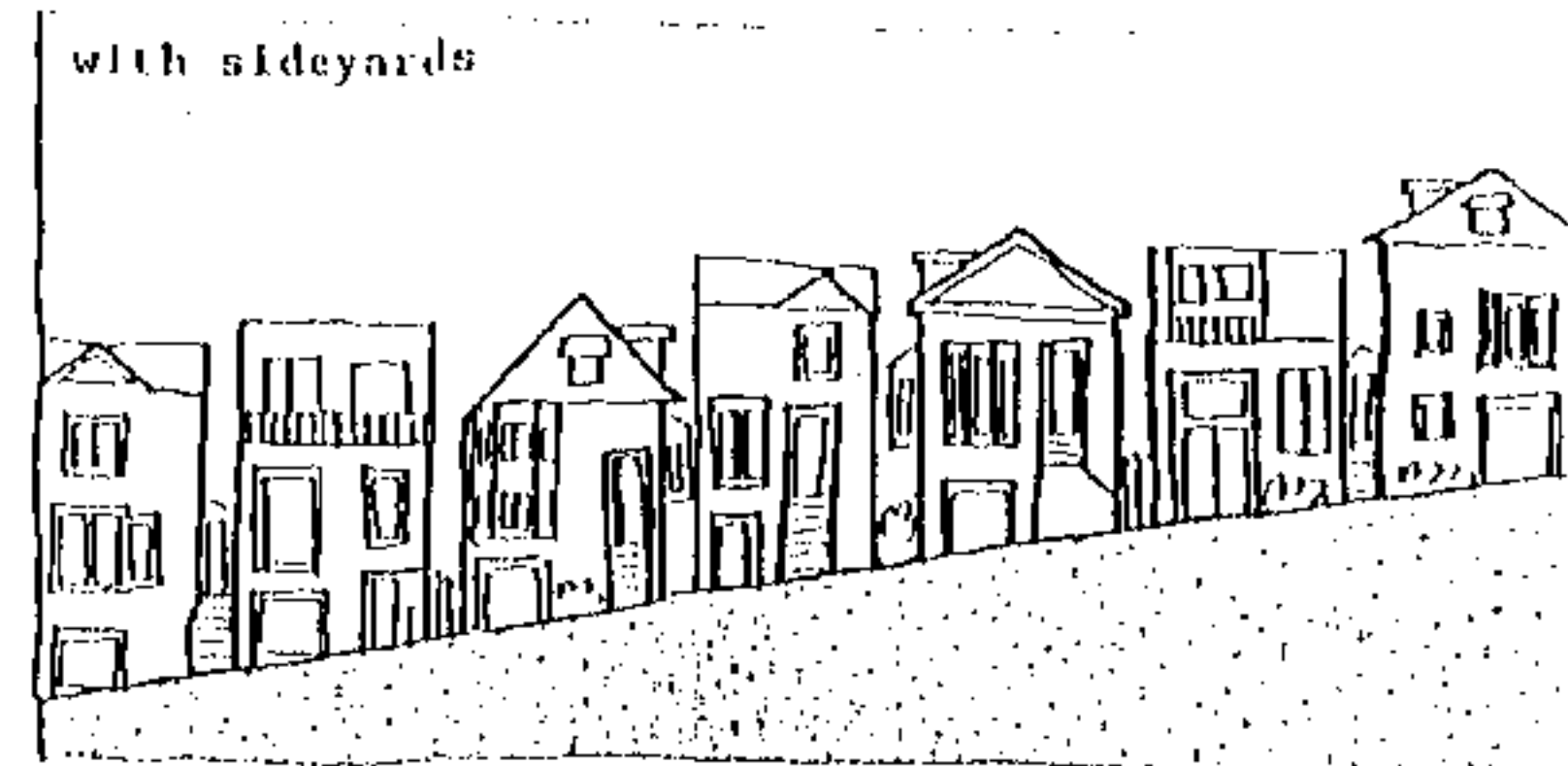
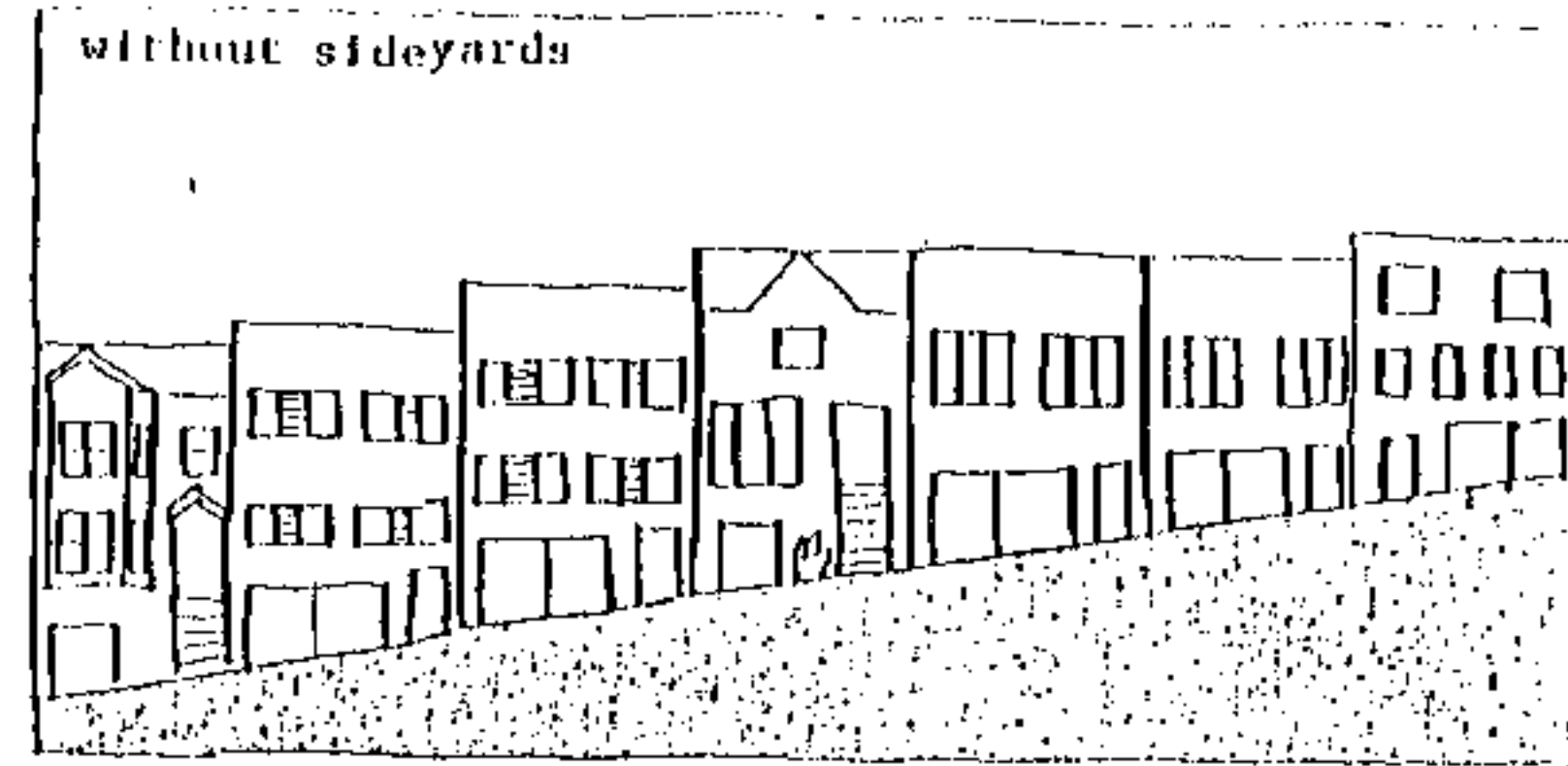

To get light, sun, air and views into and out of buildings:

5. by the use of bays on the side; and,
6. by providing a third wall on which to place windows.

To create a more diverse street character:

7. by allowing views to the east (towards Bernal Hill) and views to the west (towards Twin Peaks) for pedestrians walking along the block;
8. by increasing possible locations for landscaping;
9. by maintaining the existing neighborhood character; and,
10. by increasing the variety of possible entry approaches.

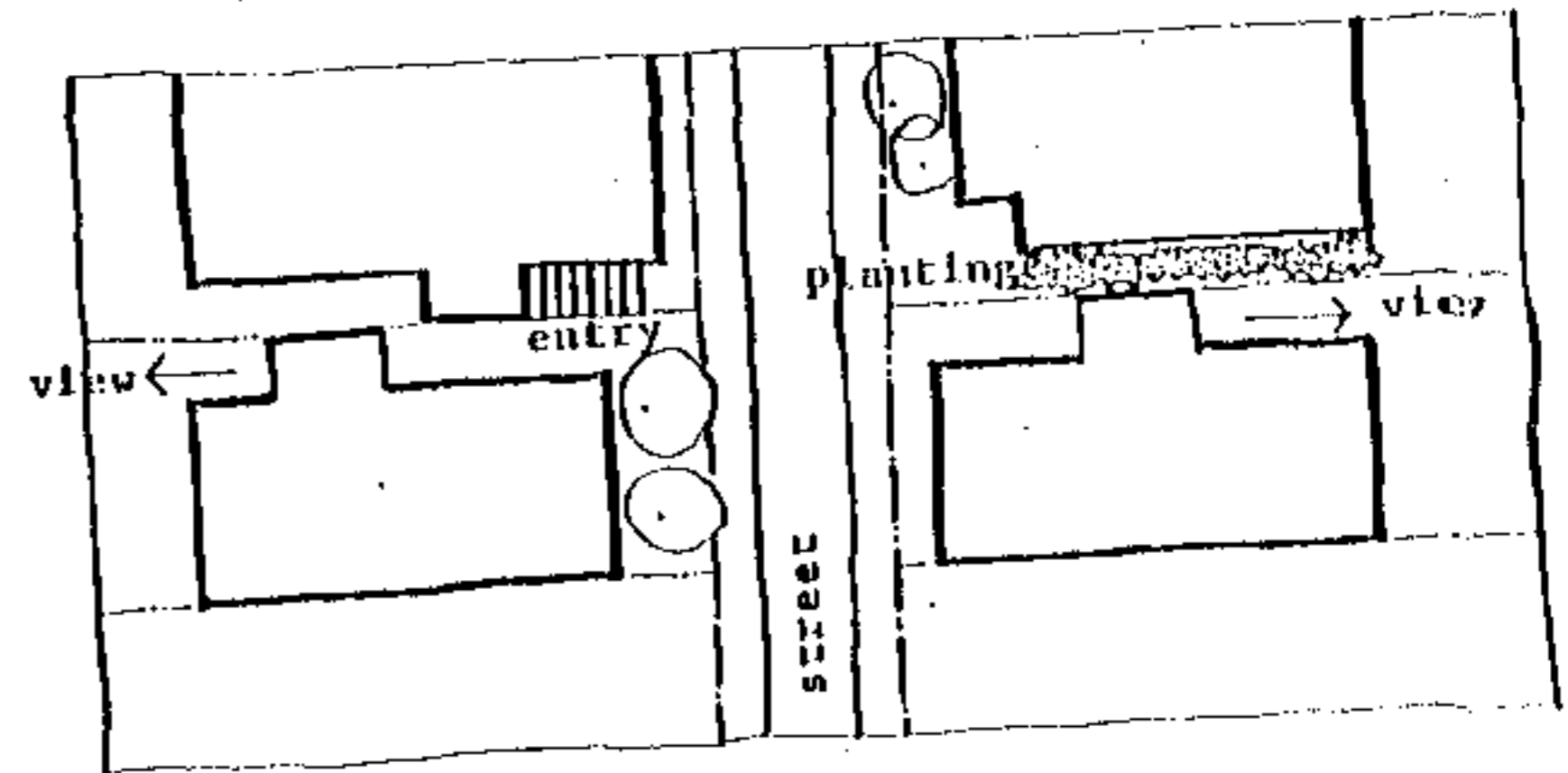
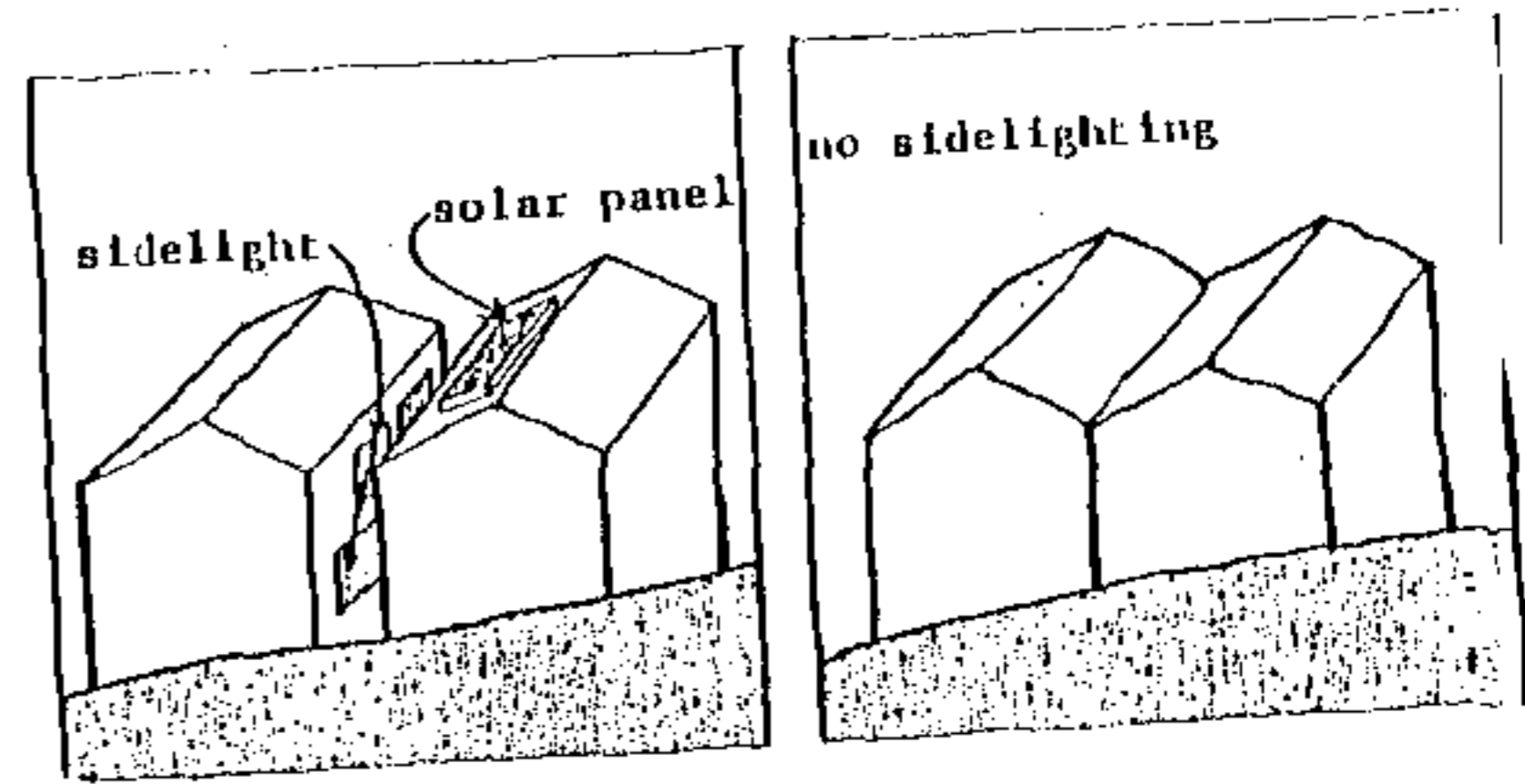

RULE:

A four foot wide sideyard is required on one side of each 25 foot lot. The first five feet back from the street facade shall be left completely open. Beyond that, two of the four additional sideyard zones must be left open. (Zone explanation follows.)

SIDEYARD ZONES

The required 4-foot-wide sideyard is divided into five zones:

Zone 1 runs the full height of the building for a depth of five feet from the street facade. No part of the building shall project into this zone.

Zone 2 is the bottom front directly behind zone 1.

Zone 3 is the top front directly behind zone 1. It must be at least 7'-6" above grade for its entire depth.

Zone 4 is the bottom rear directly behind zone 2 and extending to the rear of the building.

Zone 5 is the top rear directly behind zone 3 and extending to the rear of the building. It must be at least 7'-6" above grade for its entire length.

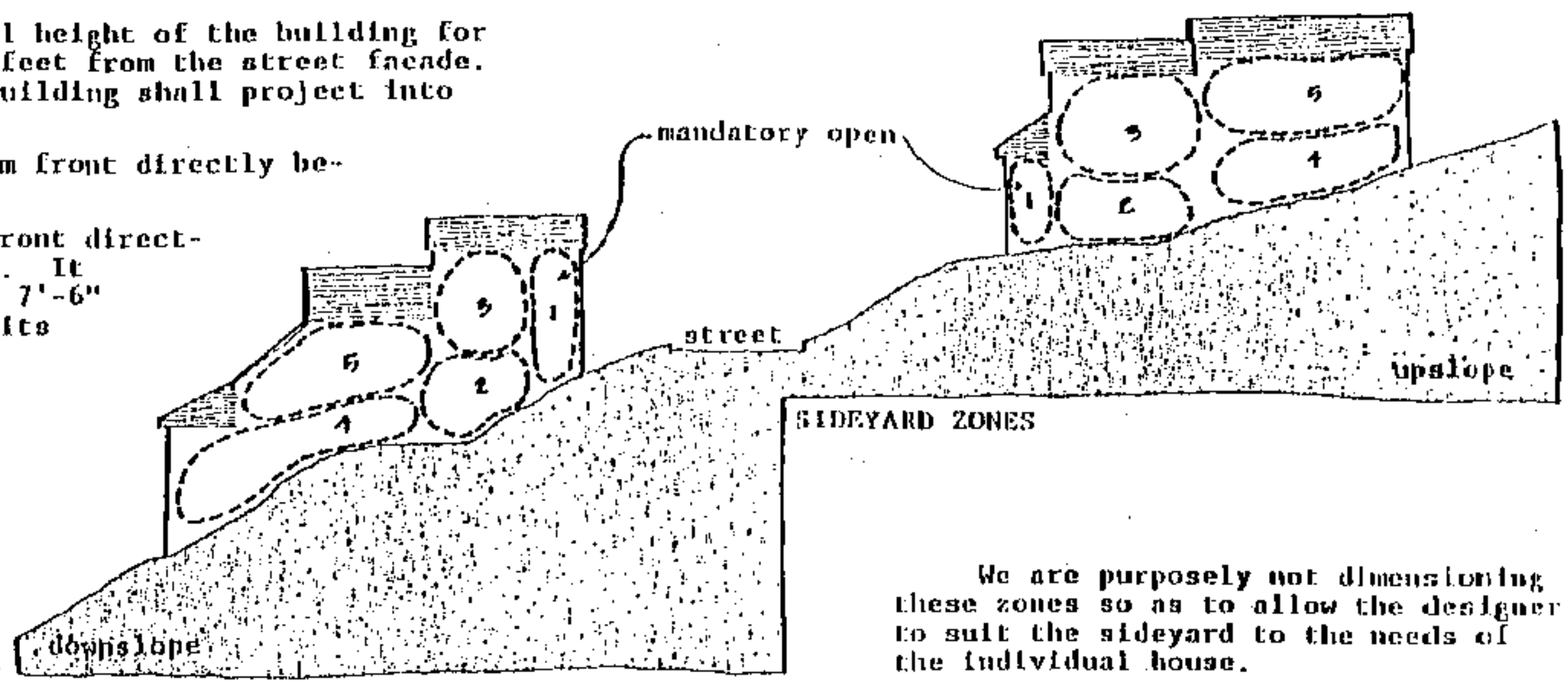

We are purposely not dimensioning these zones so as to allow the designer to suit the sideyard to the needs of the individual house.

Examples of existing sideyards and how they fit the "zone" pattern:



Sideyard for pedestrian views.
Zones: 1,2,3,4,5 open



Sideyard for planting.
Zones: 1,2,3, open

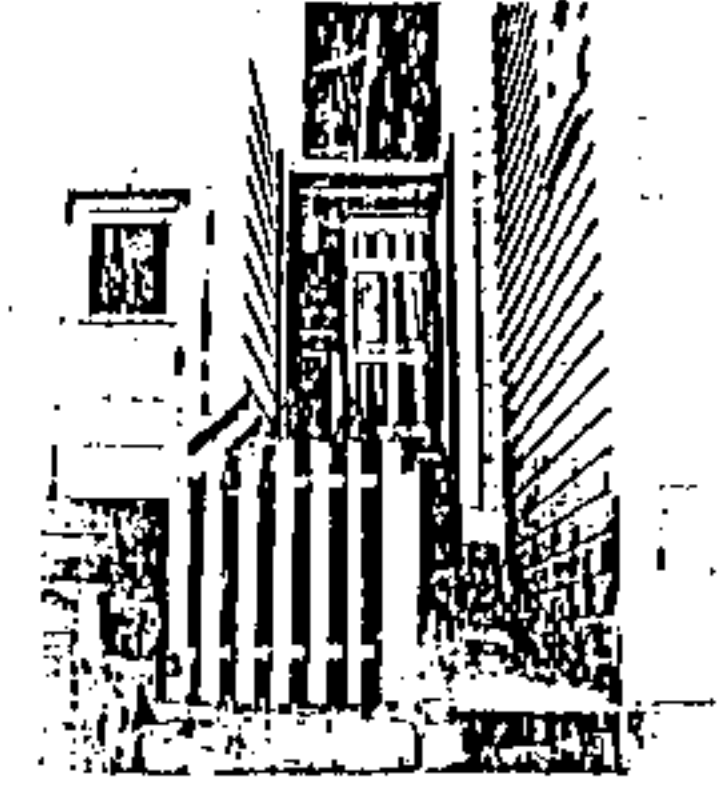

Sideyard for entry.
Zones: 1,2,3,5 open

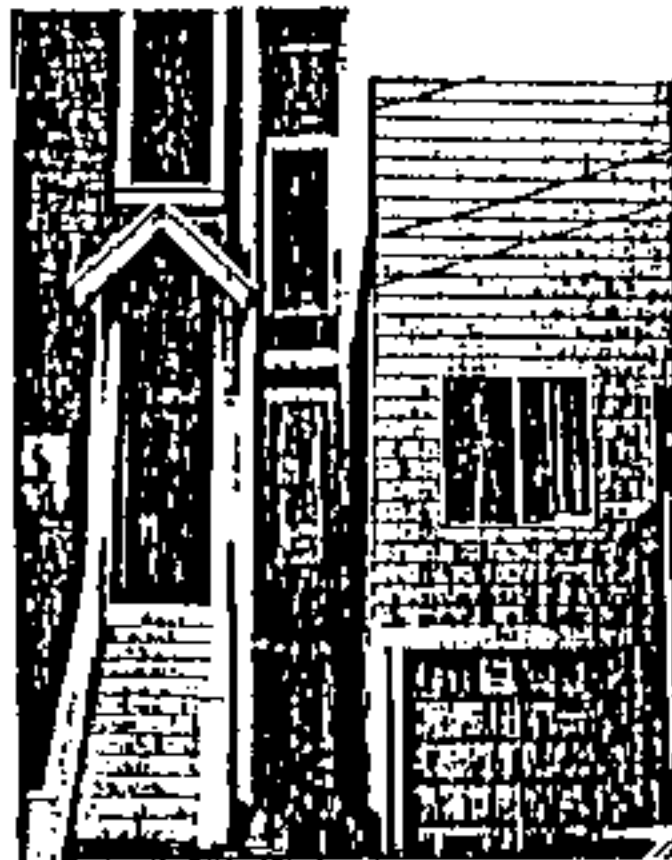

Sideyard for light to middle.
Zones: 1,2,3 open



Sideyard for access to rear.
Zones: 1,2,3,4,5 open



Sideyard as combination
of light to middle and
access to rear.
Zones: 1,2,3,4 open

ROOF TREATMENT / STEP WITH SLOPE ALONG STREET

"A vast part of the earth's surface in a town consists of roofs. Couple this with the fact that the total area of a town which can be exposed to the sun is finite, and you will realize that it is natural, and indeed essential, to make roofs which take advantage of the sun and the air." (From A Pattern Language, page 576, Christopher Alexander, Sara Ishikawa, Murray Silverstein; Oxford University Press, 1977)

INTENT:

To encourage the use of roof gardens when flat roofs are desired, while more heartily recommending pitched roofs which gracefully step with the slope of the street and create interesting skylines.

Usable flat roofs:

- 1) take good advantage of sun and air;
- 2) provide additional space on lots which, because of their small size, are limited in their possibilities for outdoor spaces;
- 3) provide a direct flow between indoor and outdoor spaces for rooms above ground level; and,
- 4) increase possibilities for landscaping.

Pitched roofs:

- 1) provide opportunities for sidelighting through the use of dormers and skylights;

- 2) are a surface for easily mounting solar collector panels if the pitch is in the range of 38° to 48°;
- 3) reduce the visual bulk of the structure;
- 4) allow houses further up the slope to maintain glimpses of their views on either side of the ridge line;
- 5) form a diversified skyline from the street;
- 6) give a more 3-dimensional quality to the building than a flat roof does; and,
- 7) are compatible with the housing stock in the surrounding neighborhood.

PROBLEM:

Unusable flat roofs:

- 1) tend to look blocky from the street;
- 2) obscure views;
- 3) present a view of unsightly tar and gravel planes with plumbing and mechanical systems randomly strewn around for residences higher up on the slope; and,
- 4) are inconsistent with the housing stock which presently characterizes the neighborhood.

RULE:

Any roof which is not pitched at a ratio of at least one in four must be designed and surfaced so as to be usable.

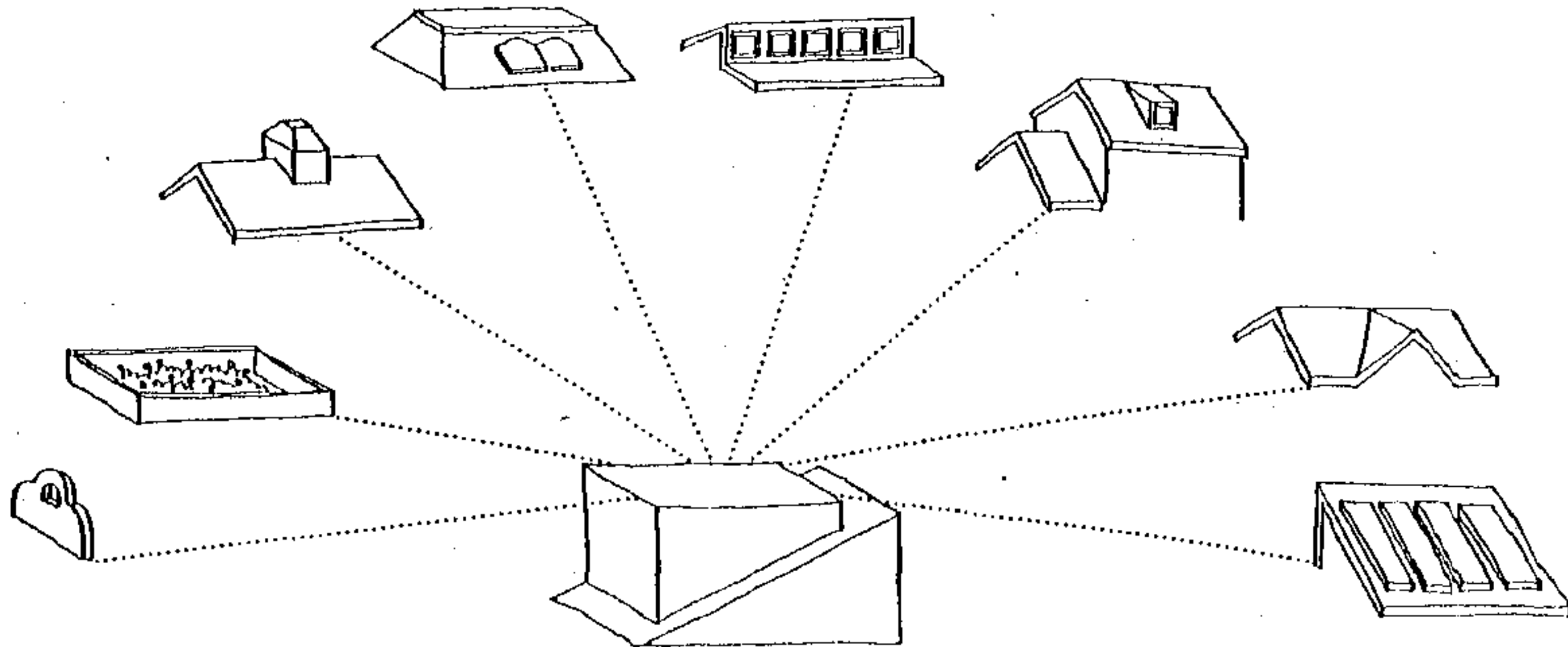

"... make it possible to walk out to the roof garden from an interior room without climbing special stairs. It is far more comfortable to walk straight out onto a roof and feel the comfort of part of the building behind and to one side of you, than it is to climb up to a place you cannot see." (From *A Pattern Language*, page 577, Christopher Alexander, Sara Ishikawa, Murray Silverstein: Oxford University Press, 1977).

RULE:

Any flat roof must be accessible from a prime living space without the necessity of climbing a special set of stairs to reach it.

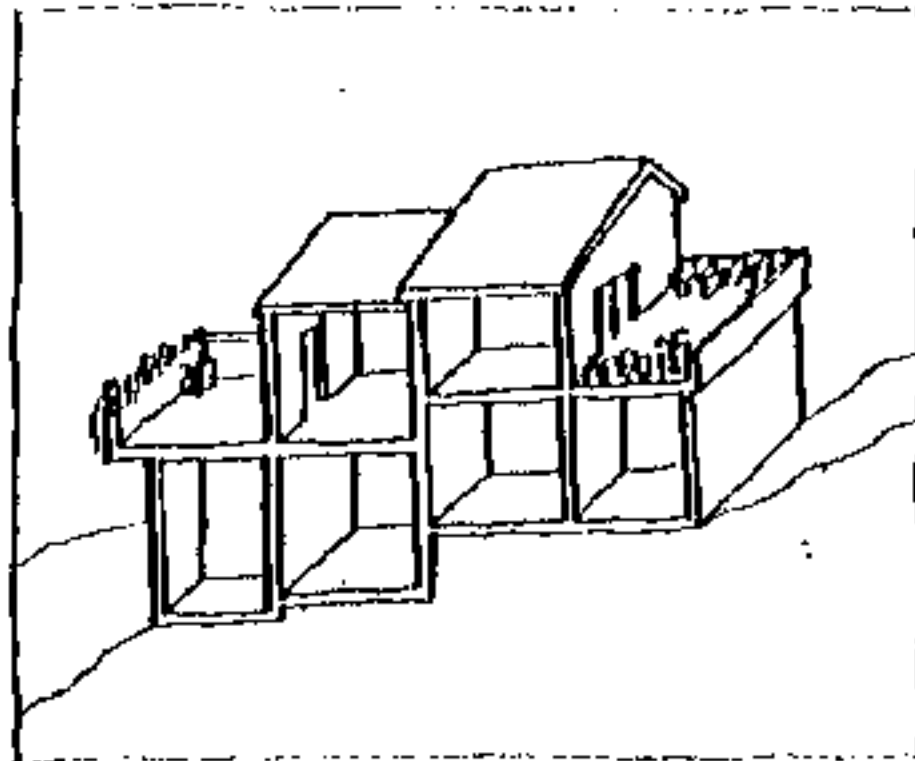

Step with Slope Along Street

One of San Francisco's remarkable features is its hills, and the grid pattern imposed upon them. Over time, builders in the City have responded to the challenge of dealing with sloping streets by stepping individual buildings up or down in a way that accentuates the unusual landforms. Present construction methods do not preclude a continuation of this practice, despite the fact that often its importance is not recognized and therefore not adhered to. When "stepping" rooflines, builders should note the incline of the slope and mimic its direction. One evident example of where this principle failed occurs on Elsie Street. In this case, two adjacent buildings were built with an effort at "stepping", but they step the wrong way. Whenever possible, new neighbors should try to coordinate their designs so that a naturally stepping skyline results.



FACADE ELEMENTS

In our attempt to analyze which architectural facade elements gave the Bernal Heights area its distinctive small-town, humanly-scaled character, we noticed a number of parts and relationships the use of which, in certain combinations, have come to serve as models for these guidelines. This guideline recommends an approach to well-proportioned, sensitively-handled design rather than a prescription of what must be done or a restriction on what is not to be done.

INTENT:

The intention here is to maximize the possibilities for diversity while striving for the harmony of unlike pieces on neighboring buildings fitting into a satisfying whole. We support the Department of City Planning's policy from its document on Potential Development On or Near the Top of Hills that "buildings, when seen together, produce a total effect that characterizes the city and its districts." (Policy 3). Though in this section of the plan we are primarily concerned with the design of individual buildings, the impact of each on the overall effect of the street cannot be overlooked. Once again, from the same document, "To conserve design character in distinctive older areas, some uniformity of scale ... is necessary." (Policy 4) One

obvious difficulty in discerning the essence of the built form of the existing houses in the area is the way in which those forms are obscured by Victorian detailing. Recognizing that these decorative features are no longer available to builders of new structures, this effort tries to distill out the form-giving elements that appear so pleasing and encourage the use of their modern counterparts in future construction.

Buildings can be viewed as aggregations of different architectural pieces. Bays, light wells, dormers, sideyards, terraces, decks, entry porches, and the like serve to break up the massing of the structure. They puncture the building, giving the planar surfaces a three-dimensionality and diminish the likelihood of monolithic box forms. Maximum envelope boxes provide no sense of depth along the street and tend to make all landscaping linear. To quote once more from City Planning policy (Policy C3), "External details of buildings provide visual interest and enrichment and maintain the historic scale and texture of San Francisco."

Many properties have been pinpointed as being particularly noteworthy of attention. The following phototrace drawings of houses in the neighborhood serve as examples of both successful and less successful composites of design elements.

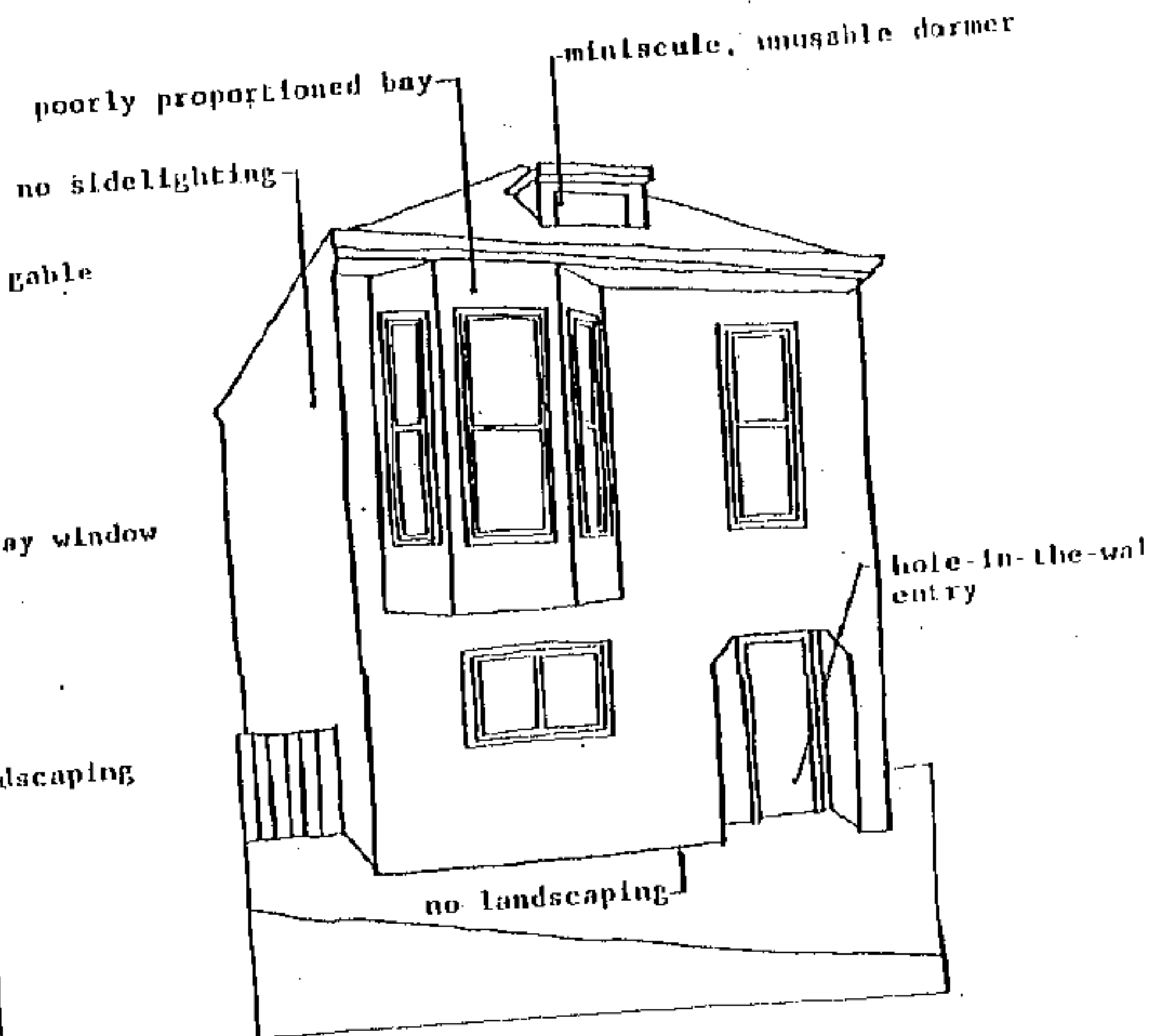
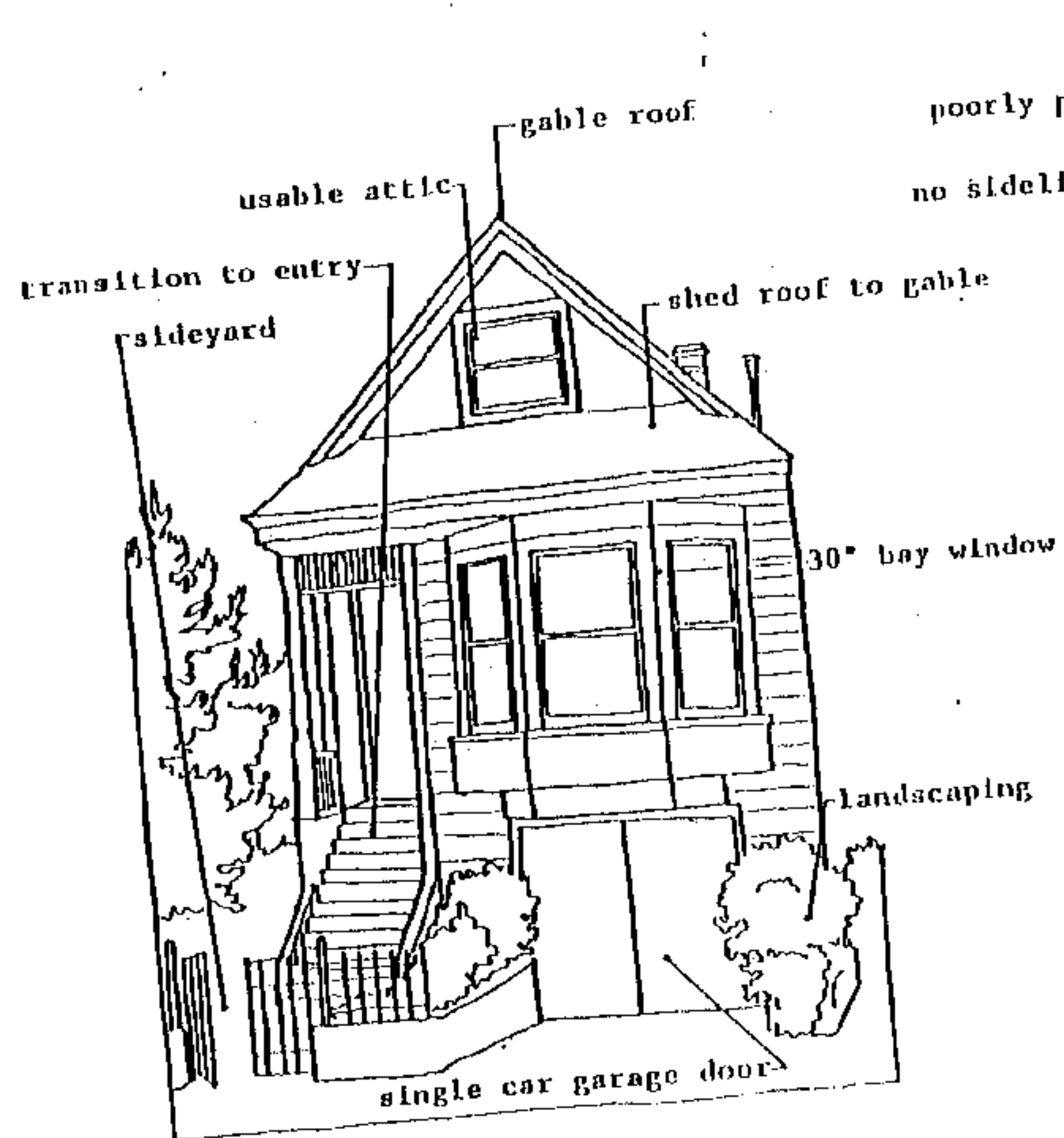

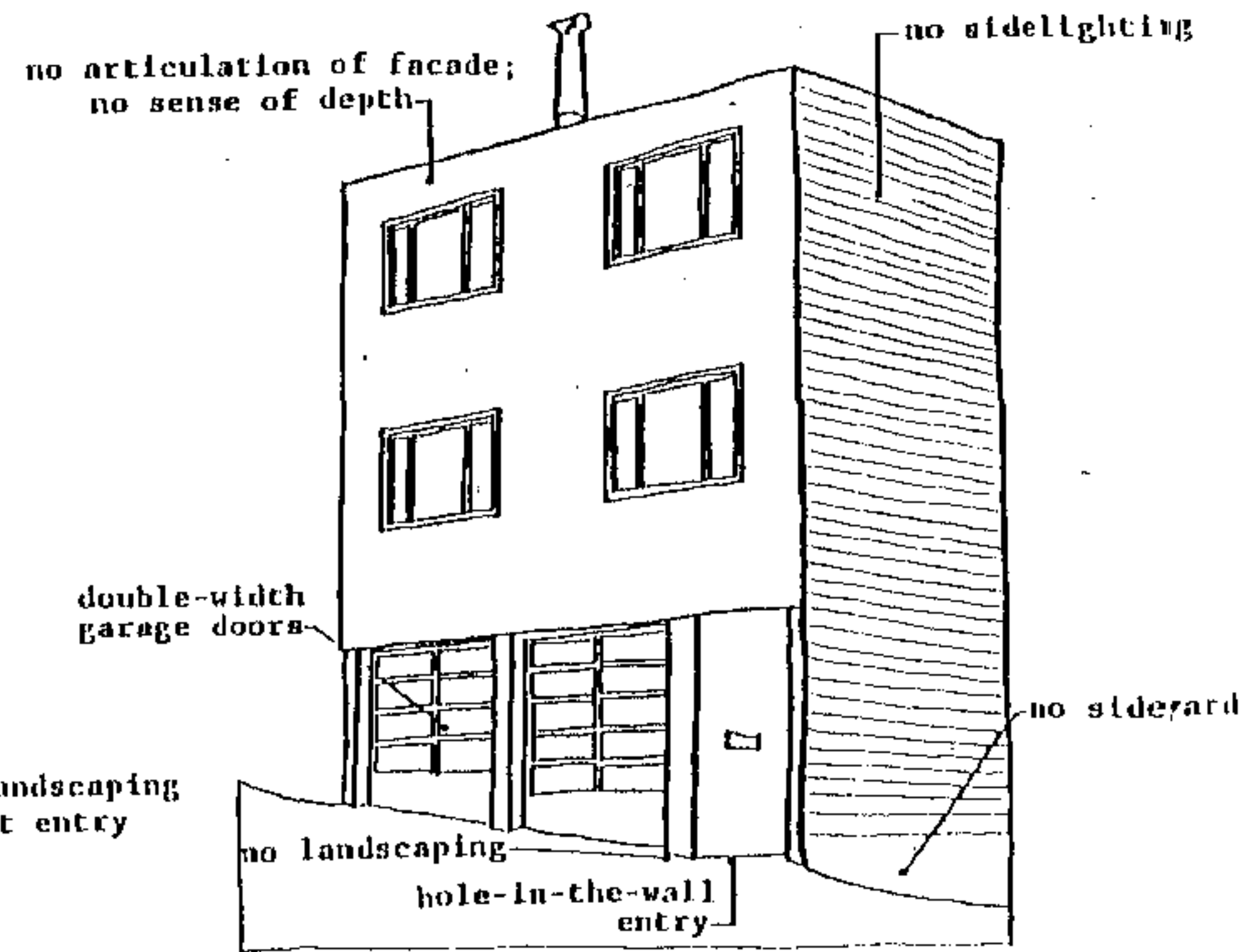
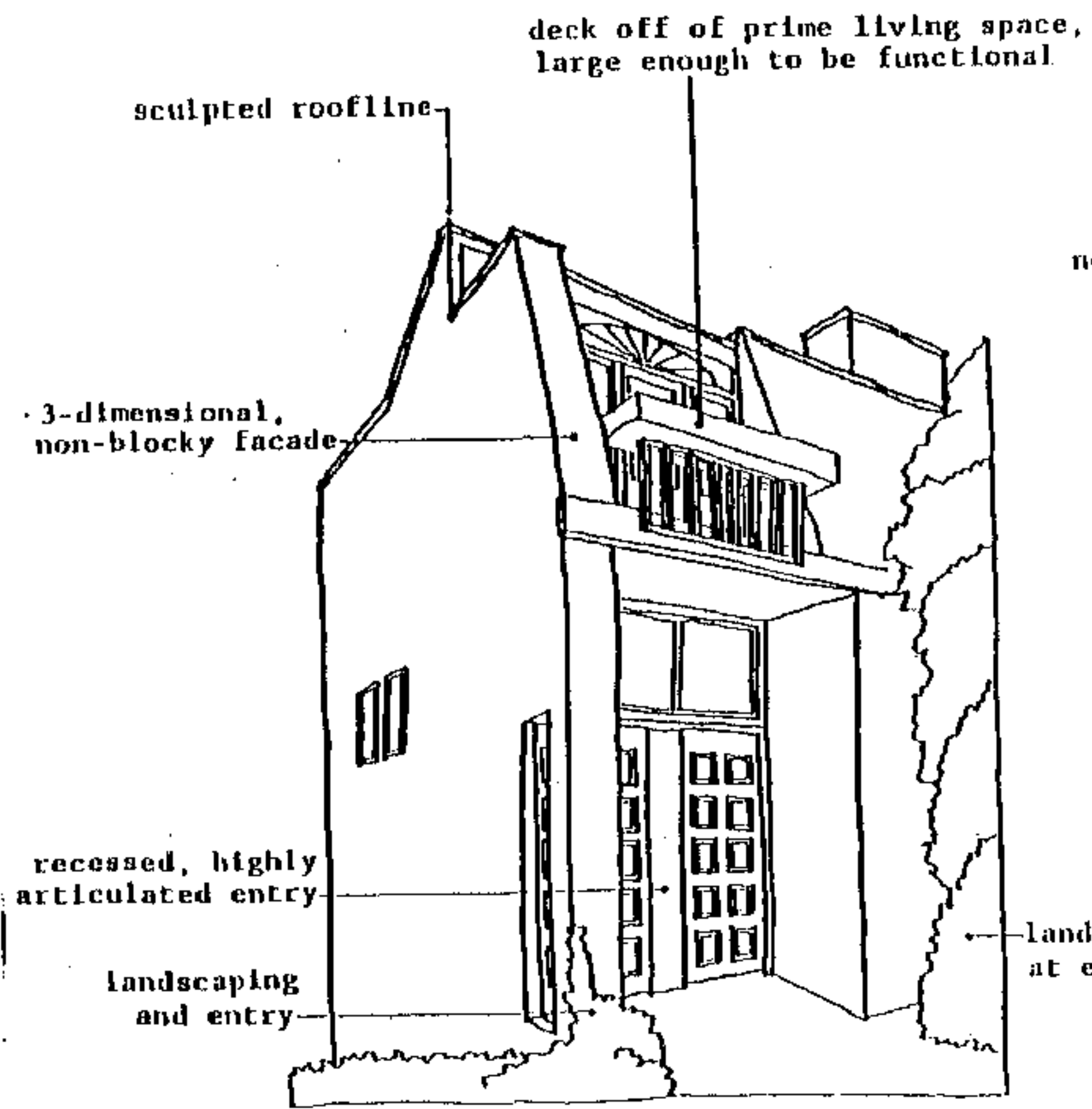

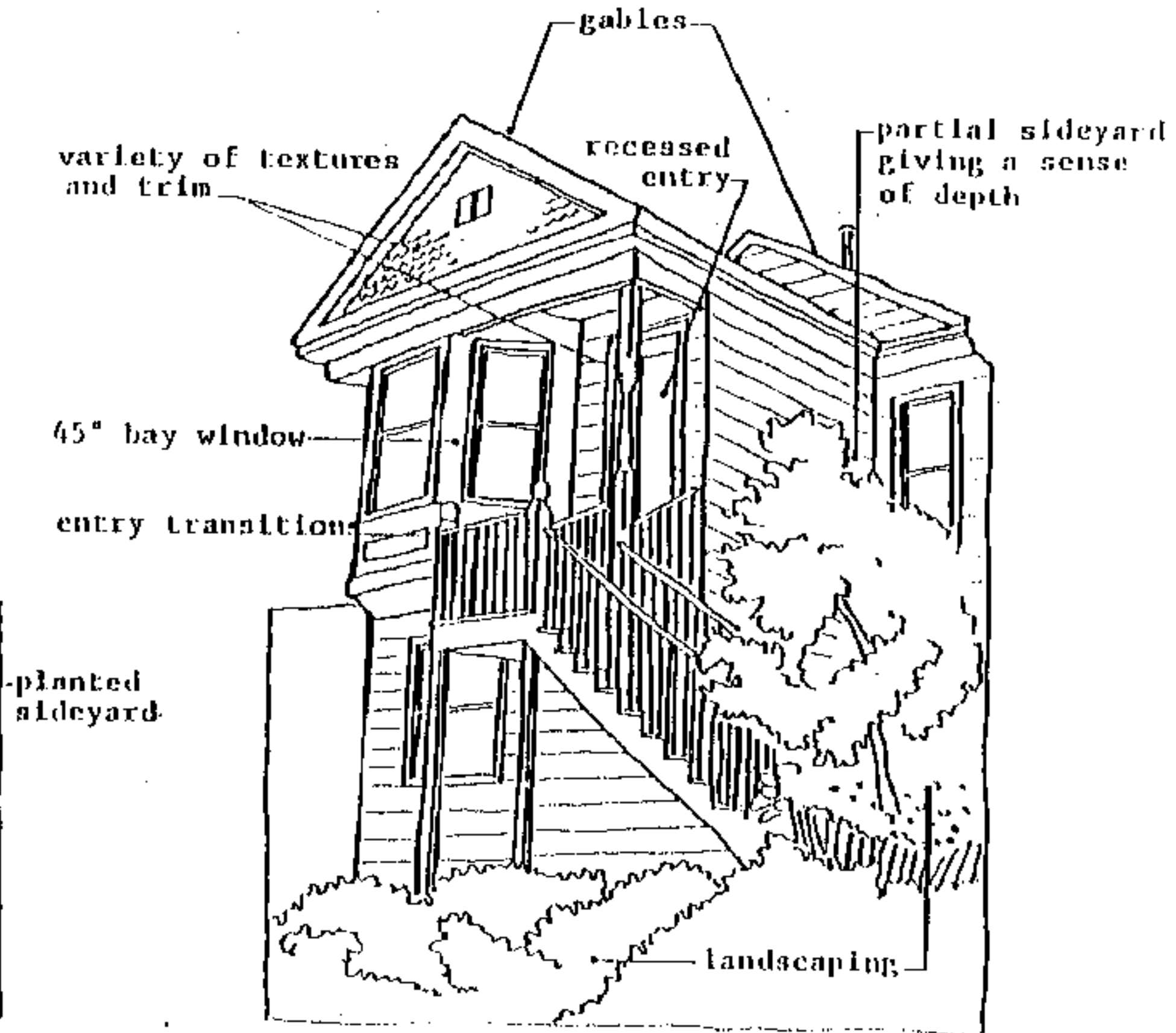
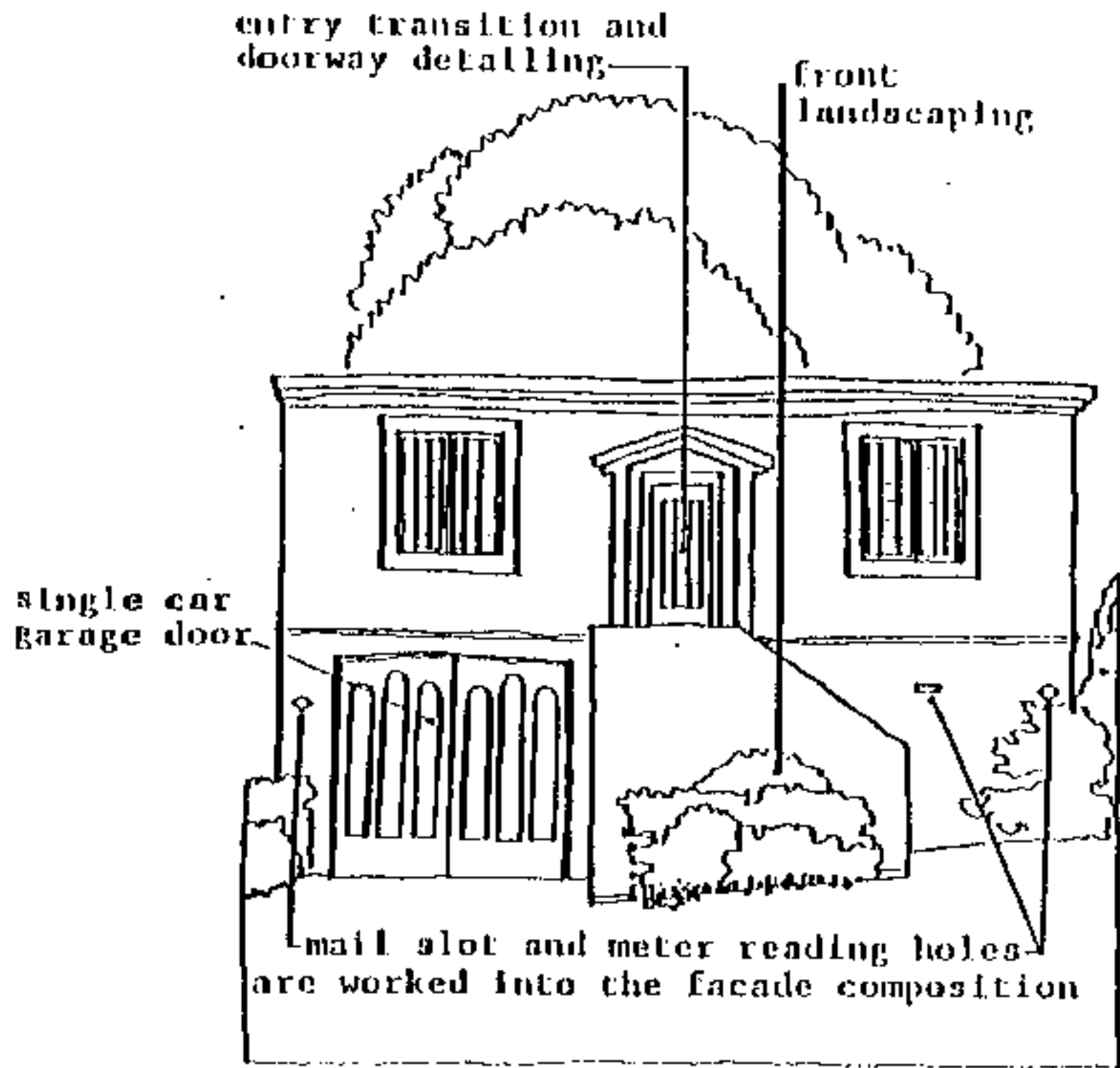

Optimally, in tackling the design of new buildings for the 100 Block of Elsie Street, owners and builders will be able to interpret the spirit of these guidelines as well as that of the surrounding homes which define the area's charm, in new and interesting ways. This involves more than merely tacking token saddlebag appendages onto box-like forms. Rather, it is hoped that the integrity of the interior flow of spaces would be reflected on the exterior, and that the shape would be determined from the inside moving out as well as vice versa. If this approach is taken, a maximum, lot-line to lot-line box would rarely, if ever, occur.

The variety of bay, entry, porch, window, roofline and garage door treatments is infinite. Bays alone can be angled at 45 degrees, 30 degrees, 60 degrees or whatever; they can be square or round-cornered; stacked, fluted or double width; flat or shed-roofed. Sunlight could enter through skylights, clerestories, lightwells or dormers, as well as via more standard framing treatments. Porches might be partially en-

closed, windscreened, or sunscreened, trellised or not. The only "rule" that is included in this section, however, does pertain to decks and/or balconies. It has been found that those which are less than 6'-0" deep are hardly ever used and become simply symbols of what they are supposed to be. Therefore, any balcony above ground level must be at least 6'-0" deep and a minimum of 36 square feet in total area.

The following diagram indicates how the maximum building bulk (as we have defined it under the "Sideyards" and "Bulk Limits" Guidelines) could be molded and shaped, with the thoughtful inclusion of elements such as bays, windows, decks, entries and so on, to come up with a product which is in line with these guidelines and the existing houses in the surrounding Elsie Street neighborhood. It should be understood that these drawings are simply a few samples of the myriad possible approaches that can be taken in any given category of design elements. The resulting "put-together" products at the end are mere schematic representations and in no way actual suggestions of what should be done.

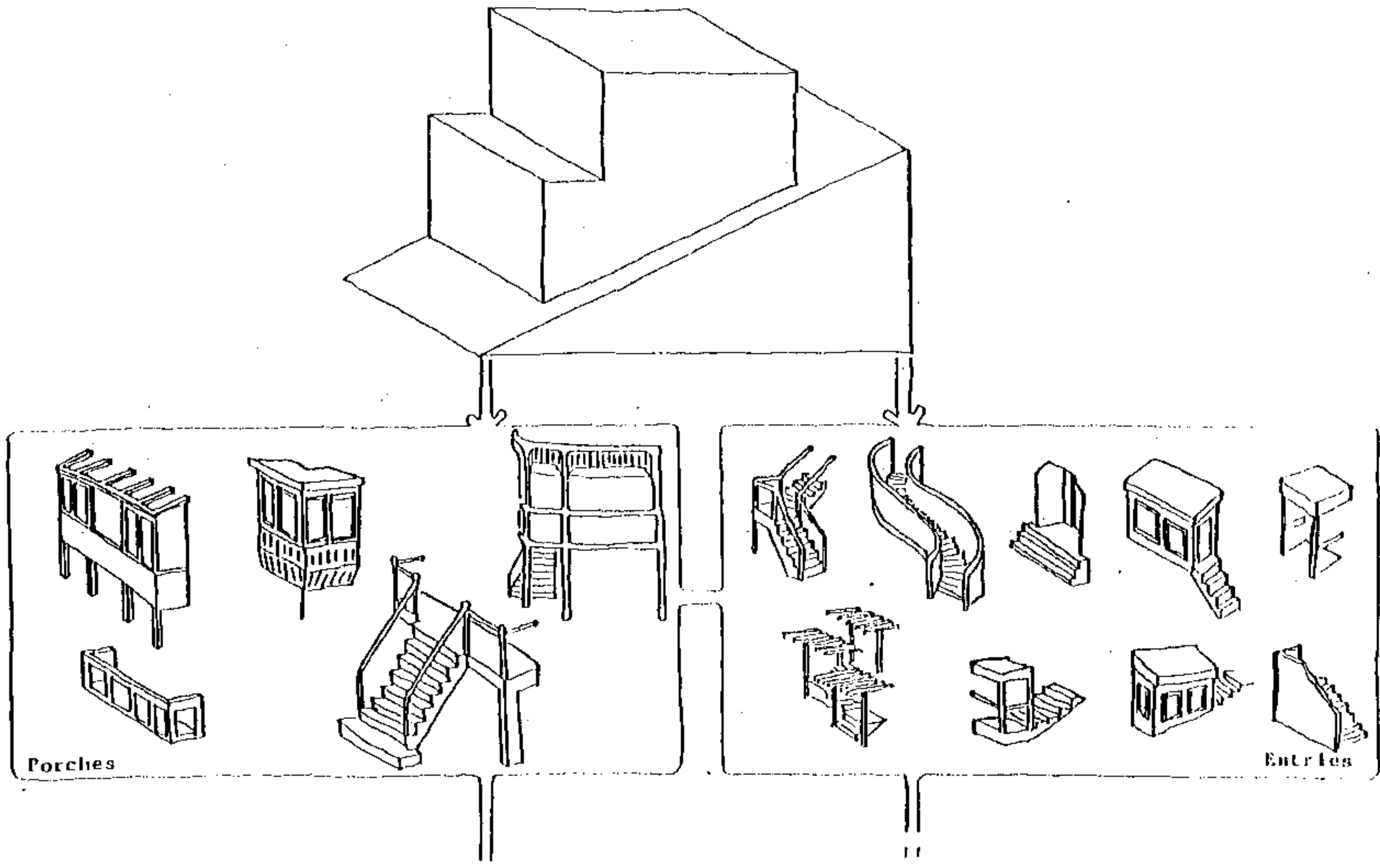

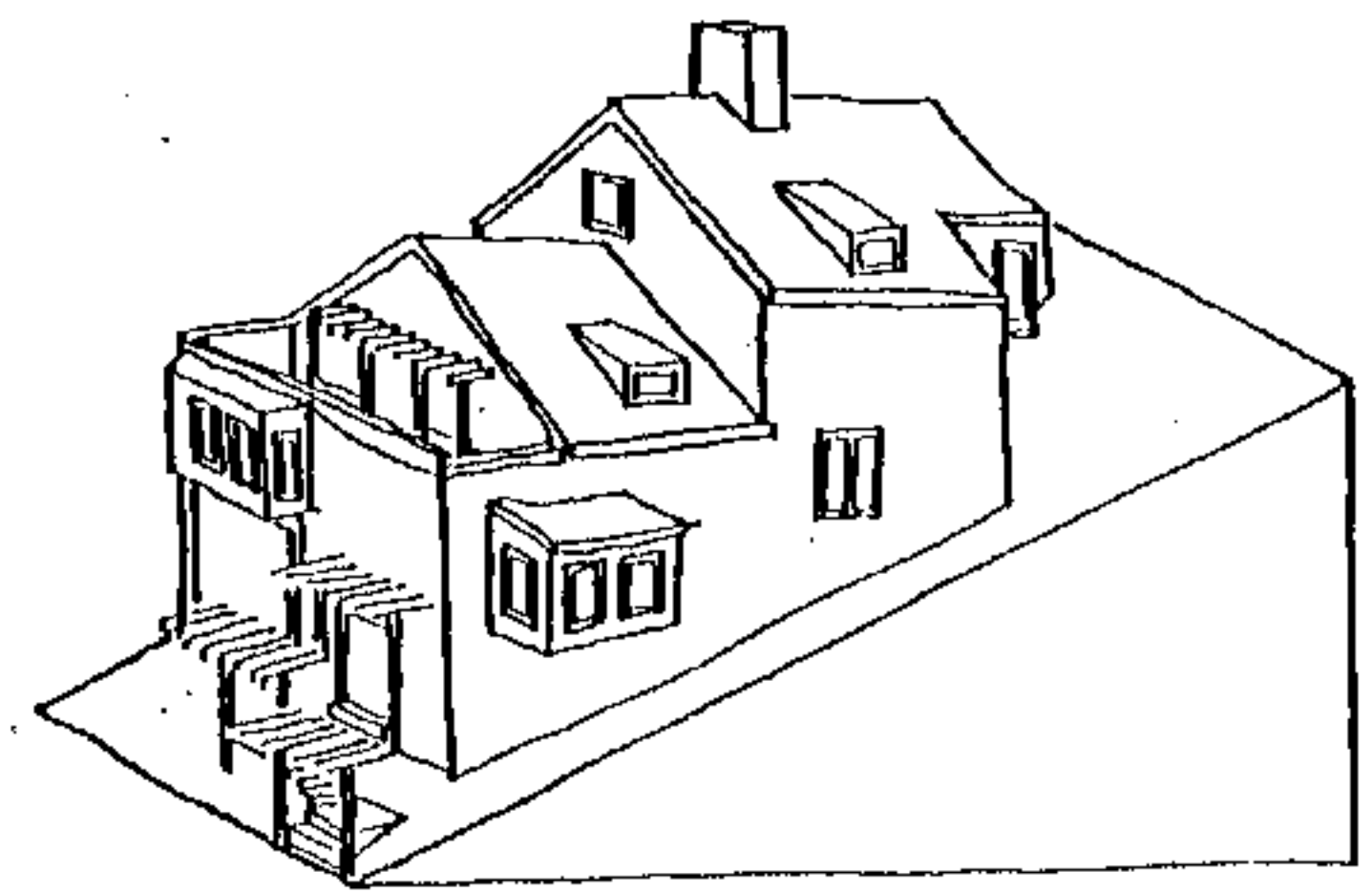
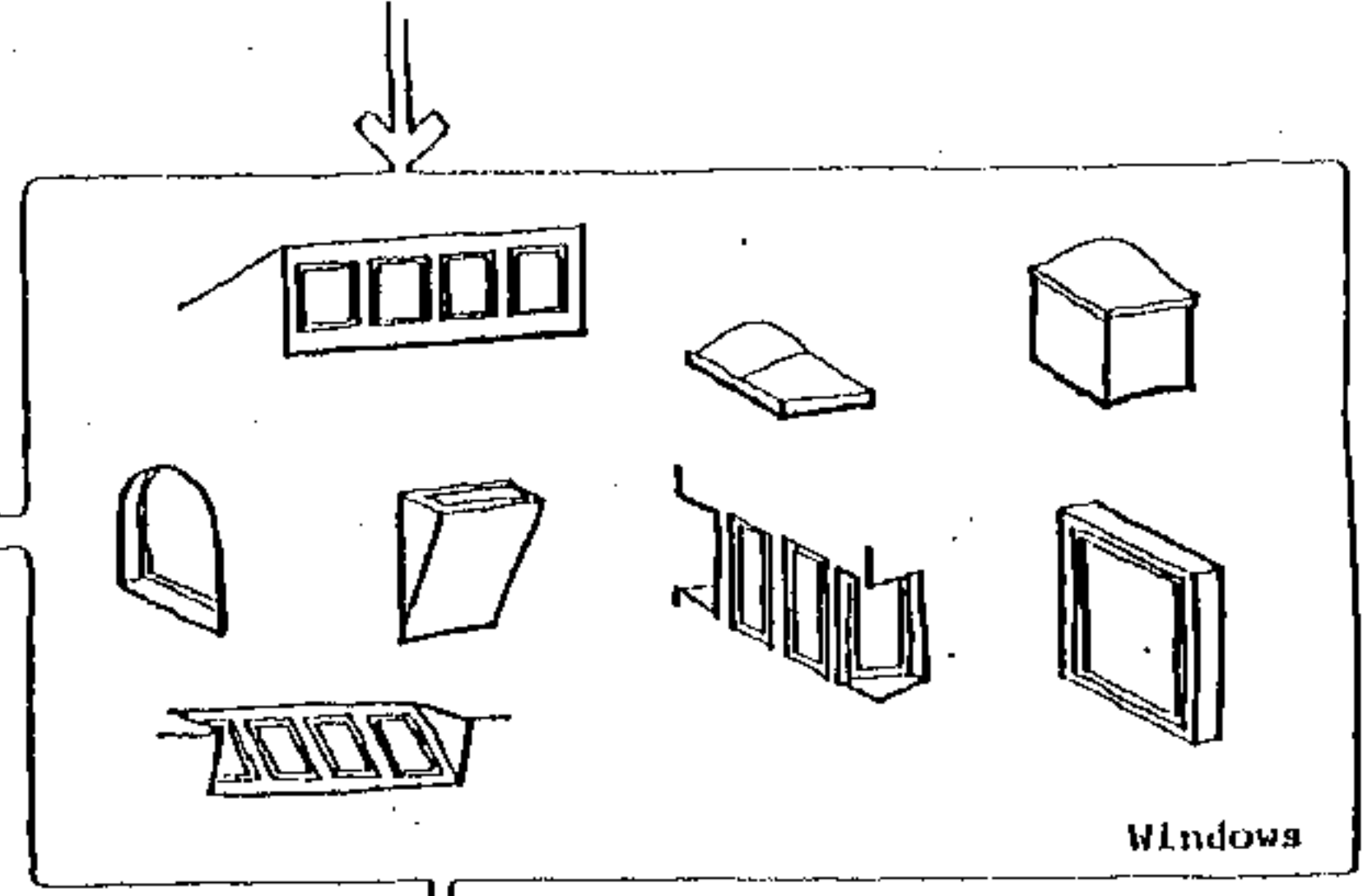
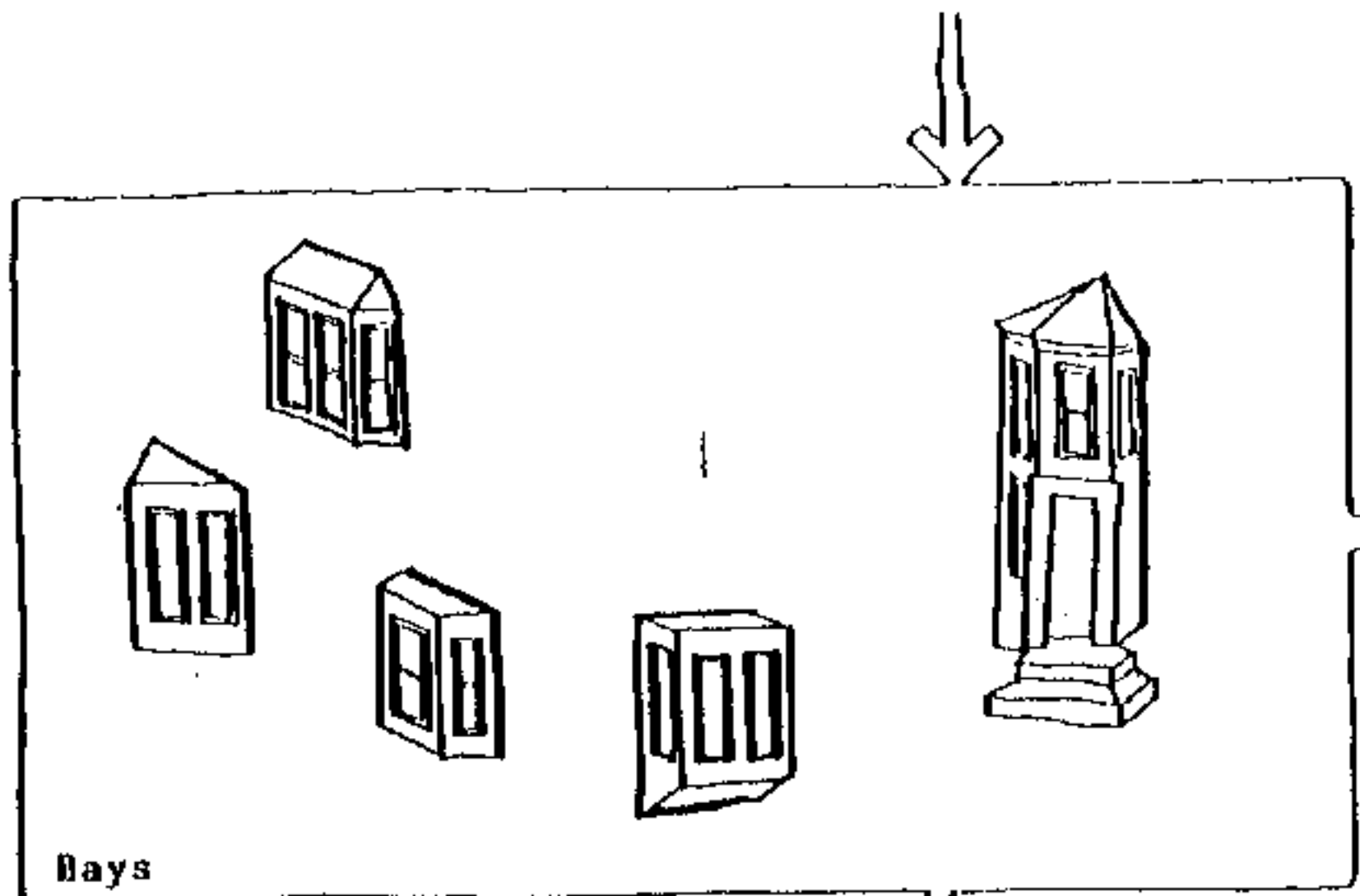

Upslope lot

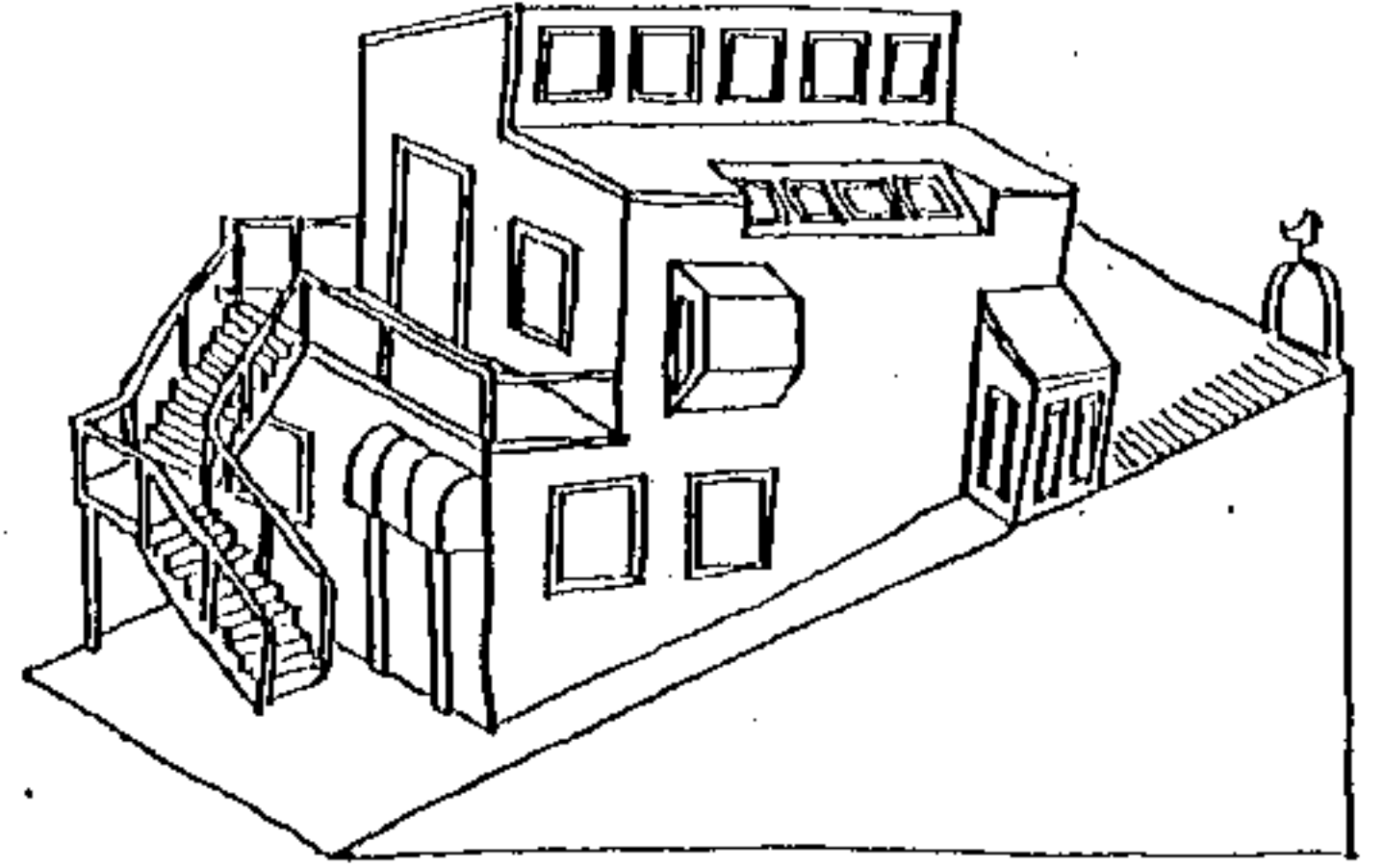

Downslope lot

COLORS & MATERIALS

Choosing the colors and materials to clothe the exterior of a new home is of course a very personal decision of the future owner. Determinations of what is attractive or "in good taste" are highly subjective and this study would not presume to dictate what they are. As the economics of today's building industry push many materials out of the realm of possibility, choices must be made on the basis of what is financially feasible as much as on any number of other considerations. On the other hand, a few observations and suggestions might prove helpful.

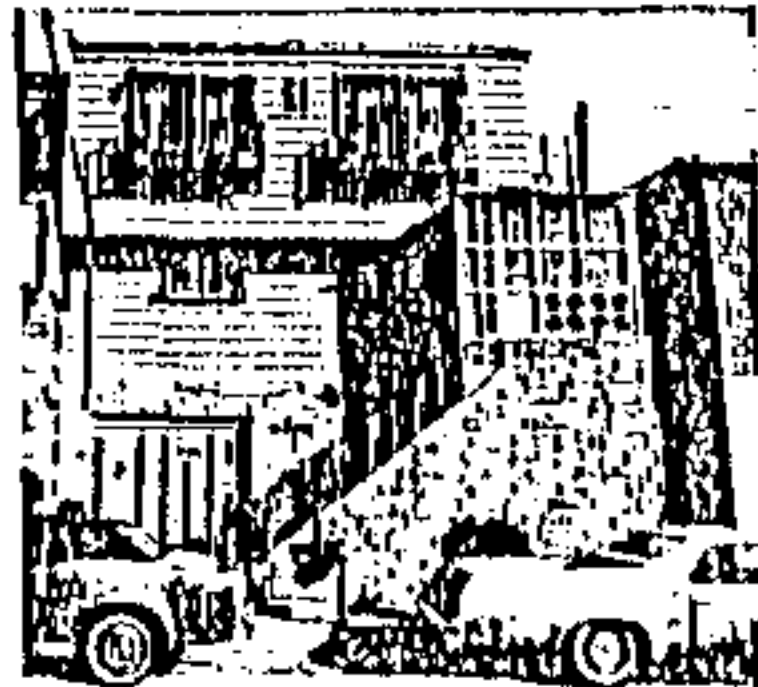

There are no intrinsically good or bad building materials. It is the way in which they are used and combined with others which makes all the difference in the world. There seems to be a misconception floating around that the greater number of textures applied to the exterior of a structure, the more impressive the overall effect will be. In this case, less is more. This is not to imply that only one finish should be used, but rather that richness should come from the careful selection of a few complementary materials instead of from a random hodge-podge of discordant ones. The accompanying photograph may help to illustrate this point. On this building, one can point out:

fake stone veneer
thin, painted wood plank siding
concrete blocks with two holes
concrete blocks with four holes
concrete blocks with six holes
simulated stained glass
curlicued metal railings
board and batten wooden garage door

The effect created is one of confusion. It is too much.

The neighborhood abounds in wonderful combinations of every material in the book. A tour around the area prior to final selection should turn up any number of possible directions to go in and would be worthwhile for any prospective homeowner.



Two specific materials which deserve a word of caution are stone veneers and plywood. It is very difficult to use a masonry veneer, alone or in combination, well. Somehow it lacks integrity and almost always tends to look "fake". The situation is particularly bad when this finish is used over doorways or garages in a way in which real masonry could never be engineered. If one wants the "look" of brick or stone, realize that special handling is necessary to pull it off. Plywood, because there are so many varieties available now, has become quite common and ac-

ceptable as an exterior siding. It can be used very effectively if the detailing at the joints is dealt with. Flashing is needed between abutting sheets, but if it is left exposed, often a raw or unfinished effect results. One way to go is to use a bronze anodized finish on the aluminum which disappears against the color of the wood. Otherwise, merely painting out the seam will have a similar effect. If on the other hand, battens are applied over the joints, a patterned rhythm is set up which can be a very successful detail on the exterior surface.

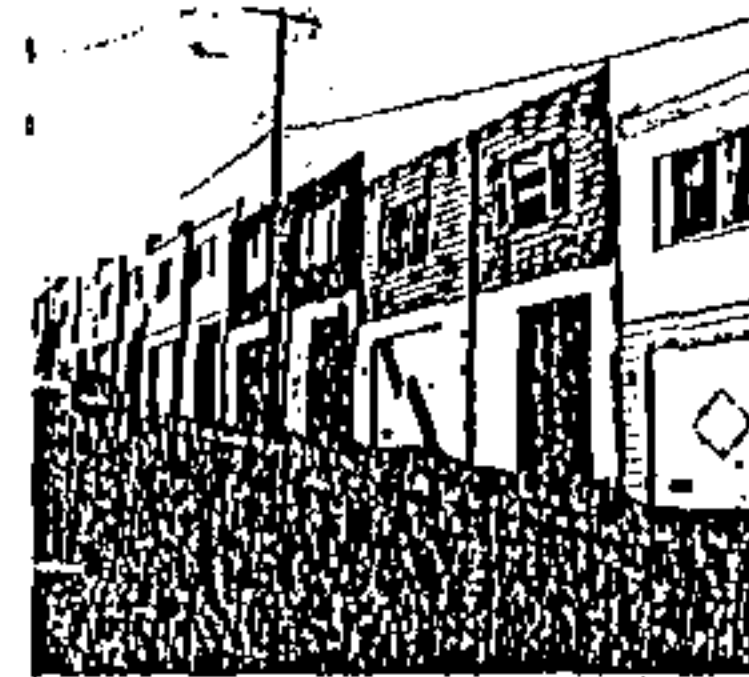

If it should happen that one builder constructs two or more homes on the 100 Block, he or she should induce diversity with more than merely token gestures. On look-alike buildings, simply changing the color of the facade or the direction of the siding or the pattern on the garage doors does not disguise the reality of the situation. It comes off as a dishonest gimmick. More substantive variation of the basic building envelope is called for in order to mesh with the existing single family character of the surrounding streets.

As for color, it should be noted that light Mediterranean hues predominate in San Francisco. For homes on the 100 Block which are to be painted, it seems particularly important to follow suit. Light shades reflect sunlight much more than dark ones do. As Elsie Street is so narrow, the more light bouncing back and forth across its 16 foot width, the better. Additionally, we have a recommendation concerning the use of paint at the base of buildings. Where more than 1'-0" of a concrete foundation is exposed above grade on the front facade of a building, the concrete should be painted. If landscaping occurs at the base, of course this would not be necessary.

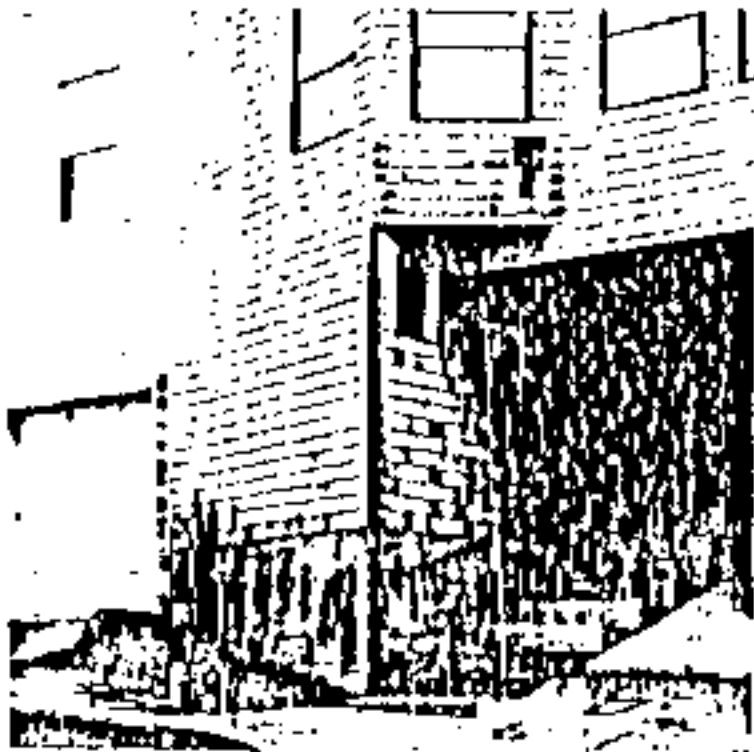

SUMMARY OF DESIGN GUIDELINES

1. 9'-0" CURB CUT/SINGLE CAR GARAGE DOOR:

Garage doors shall be limited to a 10'-0" width. Curb cuts shall be 9'-0" and placed so as to create a 16'-0" curb space within the 25'-0" width of the lot to provide one full parking space on the street. In addition, the garage door shall be placed a minimum of 16'-0" from the inside edge of the sidewalk so as to provide one additional parking place per residence in the driveway.

2. LANDSCAPING/FRONT YARD SETBACKS/STREET TREES:

Front Yard Setbacks shall be required. Minimum setbacks are as follows:

Lots 4,5,6,7,8,1112'-0"	Lot 41 13'-0"
Lot 1413'-0"	Lot 43 11'-0"
Lots 15, 17 6'-0"	Lots 48, 49, 50, 51,	
Lot 2014'-0"	53, 54, 56, 57,	
		58, 63, 64 9'-0"

50% of the Front Yard Setback area (not including the driveway up to the garage) shall have provision for landscaping (ie. trees, shrubs, flower beds, ground cover, vines, etc.).

One Street Tree shall be planted at the time of construction in front of each lot within the 40'-0" wide street right-of-way, and close to the front property line. Trees shall be 15-gallon size.

3. ENTRY TREATMENT:

Make the entry of the house something special -- a celebration -- more than just a front door. Create a transition between the street and the doorway. Give special attention to the treatment of the framing of the opening itself.

Fences or walls which enclose a lot or a portion of a lot, which run parallel to the property line on the street side, and are not structural portions of the building or the stair leading to it, shall not be completely solid at eye level.

4. BUILDING AND ARCHITECTURAL MASSING:

Step the building with the slope of the lot. Building shall not exceed 32'-0" from any point on natural grade. This height shall be measured to the average height of a pitched roof or to the highest point of a flat roof. In addition, no point of the last 10'-0" depth of the building may exceed 2/3 the height of the highest point of the structure. Highest point, once again, is defined as the average height of the pitch on a sloped roof or the highest point of a flat roof.

At the rear, a minimum 17'-6" rearyard is required.

5. SIDEYARDS:

A 4'-0" wide sideyard is required on one side of each 25'-0" lot. The first 5'-0" back from the street facade shall be left completely open. Beyond that, two of the four additional sideyard zones must be left open. (See Guideline for discussion of "zones".)

6. ROOF TREATMENT/STEP WITH SLOPE ALONG STREET:

Any roof which is not pitched at a ratio of at least one in four must be designed and surfaced so as to be usable.

Any flat roof must be accessible from a prime living space without the necessity of climbing a special set of stairs to reach it.

Step rooflines of adjacent buildings up or down in imitation of the slope of the street.

7. FACADE ELEMENTS:

Any balcony, porch, deck or terrace above ground level must be at least 6'-0" deep and a minimum of 36 square feet in total area.

8. COLORS AND MATERIALS:

Interesting facades should be generated by the careful selection of a few complimentary materials instead of by a random hodgepodge of diverse ones.

Special consideration should go into the use of masonry veneers.

Flashing between the sheets of exterior plywood siding should be detailed so as not to give an "Unfinished" appearance.

Where more than 1'-0" of a concrete foundation is exposed above grade on the front facade of a building, the concrete should be painted if the base of the home is not camouflaged with landscaping.

